

WATER ROW, GOVAN
ARCHAEOLOGICAL EVALUATION 2007
DATA STRUCTURE REPORT

DRAFT



PROJECT 2497

carried out
on behalf of
City of Glasgow Council

Contents

- 1.0 Executive Summary
- 2.0 Introduction
- 3.0 Site Location, Topography and Geology
- 4.0 Archaeological Background
- 5.0 Aims and Objectives
- 6.0 Methodology
- 7.0 Historical Research
- 8.0 Excavation Results
- 9.0 Discussion
 - 8.1 Summary of the Fieldwork Results
 - 8.2 Interpretive Issues
- 10.0 Recommendations
- 11.0 Acknowledgements
- 12.0 Bibliography
- 13.0 Appendices

List of Figures

- Figure 1: Site location with trenches and zones
- Figure 2: Historic maps: Pont 1583-96
- Figure 3: Historic maps: Blaeu 1654
- Figure 4: Historic maps: Roy 1747-55 (sheet 05/5d)
- Figure 5: Historic maps: Roy 1747-55 (sheet 15/5d)
- Figure 6: Historic maps: Richardson 1795
- Figure 7: Historic maps: Ainslie 1800
- Figure 8: Historic maps: Forrest 1816
- Figure 9: Historic maps: Thomson, 1820
- Figure 10: Extract from George Martin's 'Map of Glasgow published 1842 (Mitchell Library DTC 13/23C-J)
- Figure 11: Ordnance Survey first edition 1:2500 (1856-58)

- Figure 12: Ordnance Survey second edition 1:2500 (1895-96)
- Figure 13: Ordnance Survey third edition 1:2500 (1905-10)
- Figure 14: Ordnance Survey fourth edition 1:2500 (1938-39)
- Figure 15: Map of the Village of Govan drawn by W.D. Barles in 1906 (Govan Reminiscence Group)
- Figure 16: View of Govan waterfront from the east showing fishermen at work in front of their hut on the shore. In the background, part of the Doomster Hill and Reid's dyeworks can be seen to the left of the hut. Part of Water Row is visible to the right (Mitchell Library, Glasgow; EGV 341)
- Figure 17: Extract from Watercolour by William Simpson of the Govan waterfront from the east in 1845. In the middle distance is the fenced Old Yard and, at the water's edge, the ferry slip. Further in the distance, the light-coloured building marks the end of Water Row. The steeple of Govan Old punctuates the skyline. The long building in the foreground is part of Reid's Dye Works. (Mitchell Library, Glasgow; Mitchell ref. – EGV 476)
- Figure 18: View along Manse Lane (now Pearce Lane) looking east from Water Row, by J.P. Main, 1870. The buildings on the left, including Moses Waddell's Inn on the corner, are angled to funnel traffic towards Govan Old. The gate in the distance leads through the manse gardens and then into the churchyard (Brotchie 1938)
- Figure 19: George Martin's map of 1842, showing location of dye works and possible location of Doomster Hill
- Figure 20: Ordnance Survey first edition 1:2500 (1856-58), showing expanded dye works, new Hillock House and possible location of Doomster Hill
- Figure 21: 'A view of the banks of the Clyde taken from York Hill' by Robert Paul, 1758. This early illustration shows the Doomster Hill on the far left as a large, stepped mound. Water Row lies east of this. (Mitchell Library, Glasgow; ref. EGV 210)
- Figure 22: Area A trench 1 plan
- Figure 23: Area A trench 1 section a – a'
- Figure 24: Area A trench 1 section b – b'
- Figure 25: Area A trench 1 sections c – c' & e – e'
- Figure 26: Area A trench 1 section d- d'
- Figure 27: Area A trench 2 trench plan and north facing section
- Figure 28: Area A trench 3 trench plan and part of north facing section
- Figure 29: Area A trench 4 trench plan and part of north facing section
- Figure 30: Area A trenches 5 & 7 trench plan with north facing section and A7 east facing section

- Figure 31: Area C trench 1 trench plan and west facing section
- Figure 32: Area C trench 2 trench plan and detail of south facing section
- Figure 33: Area C trench 3 trench plan and detail of east facing section (south & north)

List of Plates

- Plate 1: Photograph of the nineteenth-century Govan Manse, 1858, from the south (Source: Transactions of the Old Govan Club 1923, Glasgow University Library, Department of Special Collections)
- Plate 2: This high-level view, looking towards the River Clyde, shows Water Row. The two-storey building is the Ferry Inn. A number of shipyards are visible in the background, and the gate to a small boat builder's yard is visible at the bottom left (Mitchell Library, ref. C1750)
- Plate 3: Trench A1 general view from NW
- Plate 4: Trench A1 general view from W with line of the 'ditch' shown by the white sand
- Plate 5: Trench A1 detail of W section with possible old ground surface
- Plate 6: Trench A1 section through the 'ditch' from the S
- Plate 7: Trench A south – location of earlier wall from the SW
- Plate 8: Trench A1 south – detail of earlier wall N from the SW
- Plate 9: Trench A1 south – detail of earlier walls S from W
- Plate 10: Trench A1 south – detail of earlier walls S from S
- Plate 11: Trench A1 northern extension with culvert from W
- Plate 12: Trench A1 northern extension detail of natural sands
- Plate 13: Trench A1 northern extension with brick structures
- Plate 14: Trench A5 from the NW
- Plate 15: Trench A7 showing natural sand from E
- Plate 16: Trench A6 deep deposits of brick and concrete from E
- Plate 17: Trench A2 general view from the W

Cover Plate:

Extract from Watercolour by William Simpson of the Govan waterfront from the east in 1845. In the middle distance is the fenced Old Yard and, at the water's edge, the ferry slip. Further in the distance, the light-coloured building marks the end of Water Row. The steeple of Govan Old punctuates the skyline. The long building in the foreground is part of Reid's Dye Works. (Mitchell Library, Glasgow; Mitchell ref. – EGV 476).

GUARD

© Glasgow University 2008
 This report is one of a series published
 by GUARD, Gregory Building,
 Lilybank Gardens, Glasgow, G12 8QQ

WATER ROW, GOVAN ARCHAEOLOGICAL
EVALUATION 2007
DATA STRUCTURE REPORT

PROJECT 2497

by

Stephen T Driscoll,
Robert S Will
and
Ingrid Shearer

This document has been prepared in accordance with GUARD standard operating procedures.

Author:

Date:

Approved by:

Date:

GUARD

Project 2497:
Water Row, Govan. Archaeological Evaluation

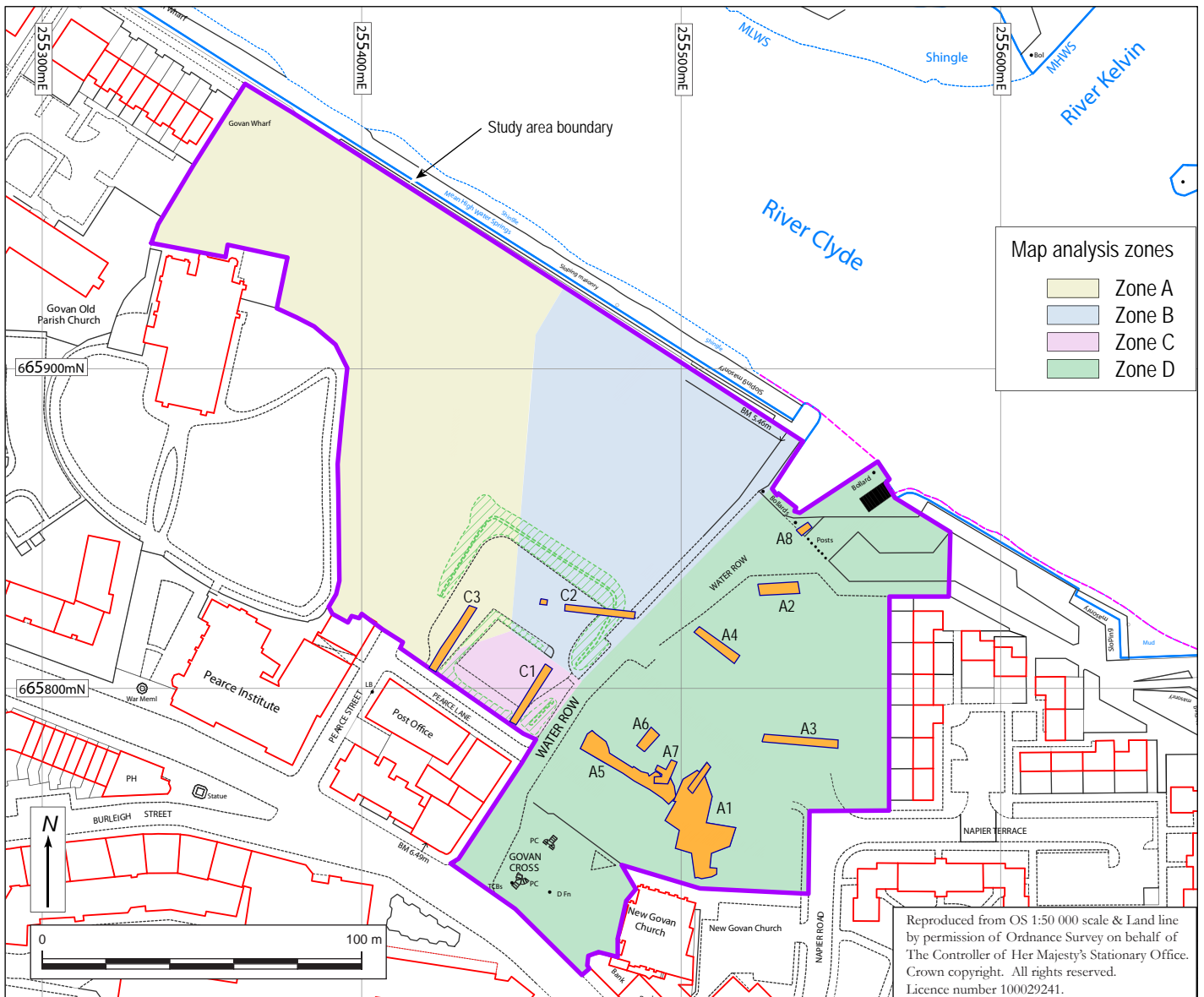
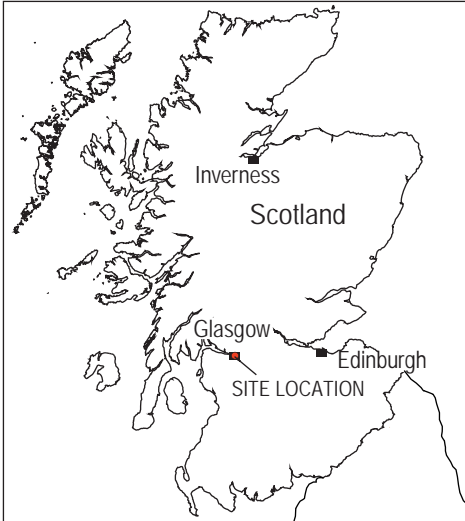

Figure 1: Location of Site & Trenches.

1.0 Executive Summary

Water Row and the central Govan waterfront were identified as a key area for redevelopment in the Central Govan Action Plan, which was adopted by Glasgow City Council in 2006. The archaeological and historical study reported on here provides a detailed evaluation of this area in anticipation of redevelopment. The study examined the cartographic evidence and archaeological resources to assess the character, survival and significance of the archaeological deposits around Water Row.

The cartographic research traces the sequence of development of Water Row from its beginnings as a ferry crossing for a rural village through a period of intense industrial growth, which culminated with the establishment of the massive Harland and Wolff shipyard. The critical period of transition, in the late eighteenth and early nineteenth centuries, is not as well documented as one would like; however, by combining the information from maps with the below-ground observations, it is possible to comment with confidence about the nature of surviving archaeological remains in the study area to the east of Water Row. For various logistical reasons, only limited excavation was undertaken to the west of Water Row; consequently, our understanding of the archaeological resource there is less secure.

1.1 Discoveries

The most significant discovery was the survival of two late Medieval or early modern buildings (possibly cottages) at the south end of the study area, which are not recorded on the earliest maps. Nearby, large quantities of Medieval pottery were recovered, indicating that Govan Cross was a focus for settlement in the Middle Ages.

The most significant conclusion, based on detailed map analysis and extensive archaeological investigation, was to establish that the Doomster Hill was some 60 m further east than was previously believed. The cartographic information does not allow the site of the Doomster Hill to be established with great precision, but it is now believed to have stood to the east side of Napier Road, where it is partially covered by modern housing. It may just fall within the study area in the extreme south-east corner. Ground testing is required to establish its precise location. An archaeological investigation to establish whether any traces of the Doomster Hill survive would be a high priority for managing Govan's heritage.

Elsewhere, substantial remains associated with Reid's Dye Works were examined. While these had been levelled by the later shipyards, considerable evidence for this early industrial activity survives. Evidence for the shipyards was less extensive and concentrated around the southern perimeter of the study area. The archaeological value of the dye works is probably greater than that of the shipyard remains.

Evidence documenting the transition from small cottage-like dwellings to tenements was found on both sides of Water Row.

The east side of the old ferry slip was located where the massive masonry retaining wall survives to its full height.

The limited work carried out on the north side of Pearce Lane suggests that construction of the Harland and Wolff plating shed swept away many of the earlier structures on the west side of Water Row; however, excavations in the 1990s established that important archaeological deposits and structures survive, particularly near the churchyard. It should not be assumed that the area west of Water Row is archaeologically sterile until appropriate investigations can be conducted.

1.2 Recommendations

It is recommended that a programme of post-excavation analysis be commissioned to report upon the artefacts and structures, in order to fulfil obligations of good archaeological practice as stipulated by the West of Scotland Archaeology Service.

A further stage of evaluation work is also recommended, to confirm the precise location of the Doomster Hill and the archaeological potential of the north-east portion of the study area (Zones B & D), which was unavailable for this study.

An outline programme of mitigation work is proposed to accompany the redevelopment of the Water Row site, including:

- Full-scale excavation of the significant Medieval and later structures to the north of Govan Cross.

- Selective excavation of the sites of tenement buildings, cottage-style dwellings and commercial buildings on both sides of Water Row.
- Monitoring of the industrial remains encountered as the site is stripped and prepared for construction.
- Exposure of the former ferry slipway with a possibility of retention.

2.0 Introduction

Four weeks of archaeological trial trenching were undertaken by Glasgow University Archaeological Research Division (GUARD) between 22 October and 16 November 2007, along with targeted historical research at the proposed development site centred on Water Row, Govan. The work was commissioned by Glasgow South West Regeneration Agency on behalf of Glasgow City Council, who are currently developing plans for the regeneration of the area. The work builds upon two episodes of smaller scale archaeological investigations undertaken by GUARD in 1994 and 1996, the latter in conjunction with the Time Team. The goal of all these archaeological investigations has been to identify surviving archaeological deposits at the heart of Govan, and to assess their significance and their vulnerability to future developments.

3.0 Site Location, Topography and Geology

Water Row lies within Govan town centre on the banks of the River Clyde, centred on NGR NS 554 658 at approximately 6 m above Ordnance Datum. The underlying drift geology consists of alluvial sand and gravel with glaciomarine intertidal and subtidal clay and silt (British Geological Survey 1:50,000, Sheet 30 E, Drift). In the field the most striking of these deposits consist of fine, nearly white sands, but there are also coarser sands with gravel that tend to be orange. Elsewhere there are no sands at all, but compact clays. The scale of the work did not allow the patterning of these subsoils to be appreciated, but using machine excavation allowed the natural horizons (ie those undisturbed by humans) to be identified with confidence.

Much of the area examined was formerly occupied by the Harland and Wolff shipyard, which was demolished and levelled in the 1970s. The eastern part of the study area is heavily used as an informal car park. Car parks are also present on the west of Water Row, but most of the western portion of the study area is occupied by compounds used by travelling show people for temporary housing and storage of fairground rides and attractions. Quay walls and the former ferry landing form the northern boundary. The Govan Old Parish Church (A listed) and its burial ground (a Scheduled Ancient Monument) lie to the west of the site, on a spot occupied by a church since the sixth century AD. A number of significant historic buildings lie to the south of the study area, including the Pearce Institute, St Mary's Church and the tenement block on the corner of Water Row and Govan Road. Low-rise public housing, built in the 1970s, occupies land to the east of the site.

4.0 Archaeological Background

The principal archaeological monument relating to the study area is the Doomster Hill, which at the outset of this study was believed to have stood to the east of Water Row, immediately north of Govan Cross and St Mary's Church. Water Row, with its important river crossing, was recognised as the core of the Medieval settlement of Govan.

The *Old Statistical Account* (1795, 690) describes the Doomster Hill as being 17 feet high and 150 feet in diameter. The mound survived well enough to be mapped by Roy in his Military Survey of Scotland in the mid eighteenth century, and to be drawn by artists in the same period and as late as the early nineteenth century, but it was gradually encroached upon by later urbanisation and industrialisation of the area. In 1845 the parish minister reported that a reservoir for the adjacent dye works had been inserted into its summit. Through close consideration of the map evidence, it has been possible to identify the likely position of this reservoir and thus the Doomster Hill on the Ordnance Survey first edition map (see below). The Doomster Hill is unfortunately not clearly indicated by the Ordnance Survey and, by the time that the second edition survey was undertaken, the expansion of Napier's shipyard resulted in the levelling of the mound.

It is likely that the Doomster Hill was raised as a court hill, similar in function to the Moot Hill at Scone. The hill is likely to have been erected in the tenth or eleventh century, when Govan and Partick served as the major centre of the British kingdom of Strathclyde. It probably fell out of regular use as the political fortunes of the kings of Strathclyde declined in the twelfth century, when the centre of power on the Clyde shifted to Glasgow.

It is clear from the earliest maps that the settlement of Govan developed at the conjunction of the church, court hill and river crossing. Water Row formed organically along the track leading up from the river crossing. The preferred fording and later ferry point was probably determined by the presence of a small burn which entered the Clyde at this point. The ferry point and the Water Row developed on the west side of the burn, which has been culverted and is no longer visible.

5.0 Aims and Objectives

The general aims of the evaluation were to expose, investigate and fully record any archaeological deposits or features in the study area and to establish the spatial and temporal relationships between them and the formation processes that created and altered the site over time.

The specific areas targeted for investigation were:

- The Doomster Hill (precise position, extent, level of survival);
- Roads layout, particularly any Early Historic/Medieval connection between the churchyard and the Doomster Hill and relating to the Post-Medieval formation of a market place;
- The course and archaeological potential of a relict burn (now culverted), the Govan Water, which is the 'water' of Water Row;
- Domestic occupation (along the eastern side of Water Row);
- Inns (on the east side of Water Row);
- Reid's early-nineteenth century dye works, and
- Shipyards (from 1839 onwards).

6.0 Methodology (Figure 1)

In total, 11 trenches were excavated throughout the available area. In advance of excavation a photographic record and condition survey were undertaken at the location of each trench to help with reinstatement. As it turned out, all the trenches were excavated through the gravel or blaes surfaces of the car parks and no hard surfaces were removed. Gravel was kept separate and used to cover the surface of the back filled trenches at the end of the excavation. During the course of the excavation, all trenches were fenced off from the public with harris fencing or temporarily with plastic fencing until the harris fencing could be erected. Once in place, the fencing was checked daily for vandalism and any breaks were repaired or replaced. Information boards were hung on the fencing, along with a supply of leaflets, to provide information on the archaeological work being undertaken, and copies of the posters were given to several local community-based organisations. The machine used for the excavation was delivered to the site each morning, usually before 8 am, and collected each night after 4 pm to avoid vandalism or damage. As the area is a busy car park, the location of each new trench was fenced off early in the morning before cars started to arrive.

During the course of the excavation, the West of Scotland Archaeology Service were kept fully informed of progress and several members of staff visited regularly to monitor progress. Once work began, it was soon apparent that the agreed programme of work would have to be changed to allow more time to be spent on the Doomster Hill trenches (A1 and A5/A7), as the deposits soon proved to be more complex than anticipated. In addition, by the end of the third week, it appeared unlikely that access would be available to the area to the north-west of Water Row, next to the river and behind the Church. As a result, the trenching programme was changed to allow a larger area to be investigated while insuring that the remaining trenches provided good spatial coverage over the rest of the available area. These changes to the programme resulted in trench A1 remaining open for the full four weeks instead of two weeks as originally planned. The remaining trenches were excavated, recorded and backfilled in quick succession to minimise disruption to the car park.

The existing ground surfaces were stripped using a mechanical excavator, fitted with a flat-bladed ditching bucket, under close archaeological supervision. Overburden was then removed in spits to the surface of the subsoil or to the first significant archaeological horizon, whichever was encountered first. Exposed surfaces were cleaned by hand. Archaeological features were recorded in plan by measured drawing at a scale of 1:50 or 1:20 and by colour print, digital and monochrome print photography. Features were half-sectioned, with fills removed and sampled in spits where appropriate. Sections were recorded by photograph, by measured drawing at a scale of 1:20 or 1:10 and by written description. The trenches were then surveyed and located within the National Grid using an EDM total station

Weather conditions during the evaluation were generally good, with very little rain over the four weeks.

Spoil heaps were scanned regularly in order to recover artefacts to assist in the analysis of the spatial distribution of artefacts.

Different environmental sampling strategies were employed according to established research targets and the perceived importance of the strata under investigation. Bulk samples up to 30 litres in size were taken from features for the recovery of artefacts and plant remains (seeds and charcoal). Bulk samples were taken of the large ditch in A1 to allow the future study of macroscopic plant remains, monoliths were taken for soils analysis and a set of soil samples for OSL (optically stimulated luminescent) dating were taken. All of this was undertaken when the ditch was believed to belong to the Doomster Hill.

7.0 Documentary Research (Ingrid Shearer)

Historic and recent maps were consulted in order to establish the presence or absence of past structures and landscape features (see Appendix 13.1 for full details):

- A total of 19 historical maps held by the National Library of Scotland were accessed on-line through its website. These range in date from Timothy Pont's map of Renfrewshire, surveyed between 1583 and 1596, to George Martin's 'Map of the City of Glasgow' of 1842.
- Past and present Ordnance Survey (OS) maps were consulted on-line via the Edina Digimap service. These range in date from the first edition County Series at 1:2,500 of 1857 to the most recent National Grid edition of 1989.
- A copy of the relevant section of the Military Survey of Scotland, dating to between 1752 and 1755 and also known as the 'Roy Map', was consulted on-line via the SCRAN website.
- A systematic review of relevant documents and maps held in the Mitchell Library was undertaken. The majority of these sources are held in the TCN 14 and DTC 13 collections.
- Consultation was undertaken with Jeffrey Stone of the Department of Geography at the University of Aberdeen, regarding issues relating to Pont and Blaeu's maps. John Moore, subject librarian at Glasgow University Library, provided information concerning mapping practices and surveys of the Glasgow area in the eighteenth and nineteenth centuries.

These various maps allow a general picture of the history of the proposed development site to be drawn for the past 400 years. This analysis considers the organisation of the settlement with a particular focus on topographic detail and the location of the Doomster Hill. Critical information regarding the location of the Doomster Hill is presented in maps which pre-date the Ordnance Survey; there are significant challenges in correlating the earlier information. This section considers the issues in some detail.

7.1 *Pre-Ordnance Survey Mapping*

7.1.1 *The Pont Map*

The earliest map consulted was Timothy Pont's 'Renfrewshire' (Figure 2), which was produced sometime between 1583 and 1596. This map reveals that the basic elements of the settlement at Govan – the church and the long village stretching out to the east – were already in place by the late sixteenth century. The name 'Mekle Govan' is used here to distinguish Govan from Little Govan, later known as the Gorbals. The Clyde is shown in its pre-canalised form; the dredging and deepening works that narrowed the river channel and eradicated tidal banks and small islands had yet to begin. These islands, such as Whiteinch and Waterinch, pepper the river to the west of Govan.

Pont's depiction of the church shows a large structure, with a church sign signifying the location of an ecclesiastical building. Pont often showed parish churches and other religious buildings on his maps, but tended to depict them schematically, and most commonly showed them as free-standing structures. What is unusual about this particular representation is that Pont is concerned to depict another smaller structure appending/abutting or close by the main building, (Jeffrey Stone, University of Aberdeen, pers comm). These combined structures are set quite apart from the rest of the village and appear to be connected to each other in some way, either physically or by sharing a common function or role. The village is positioned to the north-east of the church and is represented by a series of buildings of variable size which extend in a long line running eastward, parallel to the river.



Figure 2:

Historic maps: Pont 1583-96.

Comparing Pont's depiction of the church and settlement at Govan to other villages in the area, known to have been of a similar size, it appears that he has deliberately chosen to emphasise Govan as a prominent settlement. The village street is disproportionately large and the level of detail shown is much greater than that of comparable settlements such as the Gorbals (shown as 'Little Govan' on Pont's Renfrewshire map).

Gordon's map of the 'Barony of Ranfrew' [sic], printed sometime between 1636 and 1652, is derived from Pont's map and replicates his depiction of the church and settlement almost exactly; the only difference is a minor change in nomenclature, from 'Mekle Govan' to 'Meckle Govan'.

Joan Blaeu's 'The Baronie of Renfrow' (Figure 3) from his *Atlas Novus* was published in 1654, but many of his maps of Scotland were based on the work of Timothy Pont. Blaeu depicts the church at Govan and a smaller building is shown to the east. On the Blaeu map held in the National Library of Scotland, there are faint pencil outlines of further structures, sketched in approximately the same location as Pont's village of Govan, positioned to the north-east of the church. However, the John Bartholemew reproduction of Refroana shows this feature engraved onto the plate. Jeffrey Stone suggests that there may have been two states to the Renfroana plate – the first plate appears with pencil annotations (added at a date unknown), followed by a second stage where the sketched additions were engraved onto the plate (Jeffrey Stone, pers comm).

The sketched annotations shown on Blaeu's map appear to show a semi-circular arrangement of buildings, punctuated by rectangular tower-like structures, lending a castellated appearance to the settlement. This is in sharp contrast to Pont's village, which extended in an east to west linear arrangement. There is absolutely no evidence to suggest that Govan ever existed as an enclosed or fortified settlement and it seems this interpretation by Blaeu's engravers of Pont's original map is simply a mistaken attempt to represent the village using more stylised devices.



Figure 3:
Historic maps: Blaeu 1654.

For the period between Blaeu's Atlas and the Roy Map, two further maps were consulted: John Adair's 1685 map of the west of Scotland and Herman Moll's 1745 map of the northern part of Ayrshire. Both maps give very little in the way of detail and are much stylised. Adair shows a series of rectangular structures running parallel to the Clyde, above the annotation 'm: govan', the most westerly of which appears to have a cross on the roof, presumably denoting the parish church. Herman Moll derived much of the information for his map series from the work of Gordon, Adair and in particular Blaeu. His Renfrewshire map is even sparser in detail than any of these precursors, showing only the River Clyde, the islands of Whiteinch and Waterinch and the River Kelvin, but no settlement at Govan.



Figure 4:
Historic maps: Roy 1747-55 (sheet 05/5d).



Figure 5:

Historic maps: Roy 1747-55 (sheet 15/5d).

7.1.2 Roy's Military Survey

Of the corpus of pre-nineteenth century maps of the area around Govan, General Roy's 'Military Survey of Scotland' of 1747-55 provides the most detailed view. Govan is depicted on two separate map sheets: sheet 05/6a (Figure 4) shows the area around Glasgow, in Lanarkshire and Dunbartonshire, while sheet 15/5d (Figure 5) shows the area immediately around the north and south banks of the River Clyde. Sheet 15/5d appears to have been conceived as a navigational aid for river traffic – the majority of features recorded seem to have been selected for their visibility from the water. While sheet 15/5d is much less detailed than 05/6a, the former provides an informative counterpoint to the latter in terms of significant or highly visible landmarks and topographic features along the river during this period.

In comparison to earlier maps of the area, the Roy map is by far the most detailed, accurate and precisely recorded cartographic survey. Roy's positioning of key elements of the village, such as roadways, major land divisions and larger buildings, hold up well when compared against the Ordnance Survey first edition of 1850s, surveyed a hundred years later. However, Roy's map has obvious flaws, and caution must be exercised when examining the village in detail and attempting to identify more specific features. The purpose and historical context of the survey must always be borne in mind, and while Govan has long been a strategic point for fording the river, it is unlikely to have been considered a key military interest, perhaps resulting in a more rapid and therefore inaccurate survey.

Sheet 05/6a is the first map to capture the layout and morphology of the village of Govan in detail, and along with sheet 15/5d, contains the first recorded depictions of the Doomster Hill. In the surrounding countryside, topographic features, roads, cultivation systems and field boundaries are depicted with precision and care, even providing enough detail to allow the distinction to be made between enclosed farmland and the town commons. This sheet shows the majority of buildings strung out along the Main Street in a roughly east/west arrangement. Enclosed backlands are shown at the rear of most of these buildings.

The church is depicted as roughly cruciform shaped in plan; the main building was east/west aligned with two structures projecting to the north and south midway along the main axis of the structure. However, it is possible that this depiction may be a stylised representation of the church rather than a true indication of its form. The church is shown as being set within a square shaped, tree-lined kirkyard enclosure. The angularity of this enclosure is in contrast to all subsequent depictions of the churchyard boundary, which show it as a pear- or heart-shaped feature. There are several potential explanations for this. The most likely scenario is that Roy simplified or stylised the existing form of the boundary. This would have allowed for a more rapid survey of a structure which is unlikely to have been seen as a particularly significant feature within the context of his survey remit. In addition, the south-east corner of the squared

boundary touches the line of Manse (Pearce) Lane at the same point as the current churchyard wall, which would support the theory that the squared boundary is a simplified rendition of the pear-shaped boundary.

While it is possible that at the time of Roy's survey the original boundary was defined by a ditch and that an additional square-shaped boundary existed within this ditched enclosure, this interpretation is not supported by excavation evidence, which shows repeated construction of stone boundary walls. Archaeological investigations proved the existence of a ditch-defined church boundary following the line of the wall, dating back to the eighth or ninth century AD, but it seems unlikely that this ditch survived into the eighteenth century. It is clear, however, that the boundary was seen as a significant landscape feature; it is shown on sheet 15/5d alongside the large estate enclosures of Govandale and Fairfield to the west of the churchyard, and the mound of Doomster Hill shown to the east.

The area to the south and east of the church becomes further confused when compared against subsequent maps. To the south of the church, apparently facing on to Manse Lane, is a large building or set of buildings. Given the relative size of this building, which is comparable to the church itself, we may postulate this was an attempt to represent the church manse, shown on all subsequent maps to the east of the church. This may be an error on Roy's part, or there may have been a manse on this site pre-dating that constructed to the east of the church in the 1780s/1790s. Sheet 15/5d does appear to show another building immediately to the south of the church, but on this map it is set within the churchyard enclosure. Alternatively, what appears to be a separate building may simply be the southern arm of the cross-shaped device which Roy has used to indicate the church.

A series of buildings with backlands are shown facing onto Main Street in front of the churchyard. By the time of the OS first edition, these buildings are gone. The earliest detailed survey of the churchyard (by Kyle in 1809) shows the main entrance to the churchyard as being through a large gate to the south. However, he also shows a smaller gateway at the south-eastern corner which would have exited onto Manse Lane. If this south-eastern gate was the original entrance to the churchyard, as evinced by excavation in the 1996 excavation (Driscoll and Will 1996), it may be that the houses shown on Roy were cleared when the later southern approach was established.

To the east, the north/south line of buildings making up Water Row is shown running down towards the river from a junction off Main Street. It is bisected by Manse Lane, at which point Roy shows a few buildings fronting on to the Lane, running across Water Row on an east/west axis. These buildings running across Manse Lane are likely to be a stylistic device rather than a true representation of the layout of Water Row, and are not shown on any subsequent maps. At the southern end of Water Row he shows a small square, opening on to Main Street and flanked by buildings to the west, east and north. This may be an attempt to indicate the angular kink in the line of buildings that form the eastern side of Water Row at the southern end of the street, an area known as Govan Cross. This layout can be seen more clearly on the Ordnance Survey first edition (1858) and may be the earliest representation of this space.

To the east of Water Row, an un-named, tree-lined burn flows north, disgoring into the Clyde opposite the mouth of the Kelvin. The course of the burn appears to have been captured fairly accurately when compared against the OS first edition. The burn crosses the main road in a roughly north/south orientation, then takes a sharp turn to the west, where it flows close to the backlands on the eastern side of Water Row. It then turns back towards the north-east as it meanders down to the river. Nestled in the space between the river Clyde and the crook of the burn is the large mound known as the Doomster Hill.

On Roy's map, the mound is located in an expanse of open ground by the river's edge to the east of the burn. The hill is of massive proportions (larger than the churchyard) but is represented as a flat-topped, oval feature without either step or ditch. The hill is shown almost twice as long as it is wide with its long axis parallel with the river. Unfortunately, too few of the fixed points from Roy's day survive to allow it to be used to locate the site of the Doomster Hill with any degree of precision. However, its position in relation to Manse Lane, which exits directly opposite the western end of the long axis of the mound, provides a useful point of reference.

The Doomster Hill also appears on sheet 15/5d of the Roy map. It is shown as a much smaller feature, set further back from the shore on this sheet in comparison to sheet 05/5d. However, the veracity of this map in terms of locational accuracy must be seen within the context of its role as a navigational aid for shipping. It is much less detailed, but those elements selected for inclusion were done so on the basis of their visual prominence as viewed from the water: large estate boundaries defined by tall trees, as opposed to hedges; prominent buildings by the water's edge, such as the Pointhouse or the steeple of the Govan parish church; and to the east, the mound of Doomster Hill – large enough and tall enough to be considered a landmark from the water. This map also shows the position of the church and boundaries

surrounding the estates of Govandale and Fairfield fairly accurately relative to the opposing river bank and mouth of the Kelvin, but we cannot assume that the positioning of the Doomster Hill is any more reliable than that on sheet 05/5d.

Many of the features shown on Roy's map appear to be situated too far to the north. For example, the churchyard shown on the OS first edition sits approximately midway between the Main Street and the River Clyde, whereas Roy shows this feature as positioned much further to the north in relative terms. Subsequent modifications to the Clyde may also have played a part, but the impact of land reclamation and revetment of the river banks should not be over-emphasised (see below). Similarly, the northern slopes of the Doomster Hill appear to run down almost to the river's edge, and the area around Manse Lane is also too close to the river. The accuracy of Roy's map is further undermined when we look across the river to the Pointhouse area. The northern end of Water Row sits directly opposite the confluence of the Kelvin river, but Roy has shifted the entire village of Govan so far to the west that the mouth of the Kelvin faces Doomster Hill. This may be a result of the way in which these areas were surveyed; it seems likely that the surveys were conducted separately and fitted together at a later date, resulting in discrepancies in correlating the opposing sides of the riverbank. These problems aside, Roy's survey is perhaps the last map to show, in any detail, the river and its banks in their unaltered, pre-industrial form.

On both sheets Roy shows a small indentation in the southern bank of the river, just along from the churchyard and east of Water Row. This shallow bay or bight appears on several later maps and is also represented in several later illustrations of the area, the earliest being an engraving made by Robert Paul in 1758 (see below).



Figure 6:
Historic maps: Richardson 1795.

7.1.3 Between Roy and the Ordnance Survey

For the period between Roy's map and the OS first edition map of the 1850s, cartographic sources for Govan are comparatively few. While there was a flurry of cartographic activity during this period, the majority of maps were commissioned by and focused on the city of Glasgow. Many of these maps were incredibly detailed and increasingly accurate, but unfortunately few extend further west than Anderston, and those that do contain only basic, heavily stylised information. Ainslie's 'Map of the County of Renfrew' (1800), Forrest's map of 'The county of Lanark' (1816) and Thomson's map of 'Renfrewshire' (1820) are a few of the more detailed examples from this period, although the content of even these maps is still sparse and impressionistic. George Martin's 'Map of the City of Glasgow', published in 1842, is the

only reasonably accurate and detailed depiction of the village published prior to the Ordnance Survey first edition map of 1857-58.

Charles Ross's 'map of the Shire of Lanark', published in 1773, shows the parish church in pictographic form, annotated as 'Kirk'. A few buildings are scattered along the route of Main Street, but there is no further detail and the map is at too large a scale to be useful in plotting the buildings shown. Taylor and Skinners' '...road from Edinr, to Glasgow & Greenock & to Dunbarton & Inveraray', published two years later, again emphasises the church as the significant feature in the village. Other buildings line the Main Street and there are hints of further settlement towards the river in approximately the location of Water Row, but again there is little useful detail. Thomas Richardson's 'Map of the town of Glasgow and country seven miles around', published in 1795 (Figure 6), shows the 'Kirk' and 'Manse' (set to the east of the church) as the two predominant buildings in the town. These structures are shown as pictographs, with the manse building depicted in the same format as some of the larger estate houses surrounding the village, such as Fairfield and Broomelohan. This manse building is thought to have been constructed sometime around the 1780s-90s, replacing the earlier manse presumed to have been in the same location (Dalglish & Driscoll forthcoming). This incarnation of the manse would have been relatively new when surveyed by Richardson and appears to have been a larger, more impressive structure than its predecessor, with an adjoining block of court offices. Other buildings in the village are shown in schematised blocks, lining Main Street, although Richardson does show some buildings lining Water Row and has distinguished the right-angled kink in the line of buildings along the east side of the row where it meets Main Street.

Ainslie's 'Map of the County of Renfrew' (Figure 7), published in 1800, replicates much of Richardson's content, and is similarly stylised and lacking in detail. However, it is significant in that it shows the location and character of the Doomster Hill (shown by the word 'Hillock' here), and also the un-named burn which runs between the rear of the eastern side of Water Row and the Doomster Hill. Like Roy, Ainslie depicts the mound as a massive feature positioned close to the edge of the river. The mound is shown as being much more rounded in plan than on Roy's rendition and its position has been moved further north. Roy depicts the longitudinal axis of the mound as approximately aligned with Manse Lane, whereas a line projected along the eastern exit of Manse Lane on Ainslie's map would barely touch the southern edges of the mound. Unfortunately, the distinctive kinks and bends in the burn have been simplified on Ainslie's map and cannot be used as reference points. Ainslie's map is also the first to show a series of jetties along the north and south banks of the river, introduced to channel the water course so that its natural scouring action would deepen the river.



Figure 7:

Historic maps: Ainslie 1800.



Figure 8:

Historic maps: Forrest 1816.

William Forrest's 'The County of Lanark from Actual Survey of 1816' (Figure 8) shows the Kirk and Manse in the same positions as Ainslie's and Richardson's maps, but emphasises the line of trees that defines the area to the north and west of these buildings. Indeed, Forrest populates the entire western side of Water Row with trees rather than indicating buildings, such as the eastern side of the row. This is in contrast to the open space to the east of Water Row, within which the Doomster Hill is sited. The mound, which is un-named on this map, is similar in relative size and shape to the 'Hillock' shown on Ainslie's map, but is situated further to the south (lying approximately one third of the distance down from Main Street to the river) and possibly further east than previous depictions. The southern flank of the mound appears to run into the backlands behind properties on Main Street, and sits to the south-east of two buildings set slightly back from the eastern side of Water Row. Given the simplistic and schematised nature of this map, it is impossible to get a reasonable fix on the position of the mound.

This map also shows a new road layout through the town. A little way east of the turn-off to Water Row, Main Street splits and a new, straighter road (called Main Road on the OS first edition and Govan Road now) now runs to the south, parallel to the old thoroughfare.

Govan appears on two of John Thomson's maps. On his map of 'Renfrewshire', published in 1820 (Figure 9), he shows the church, a few rectangular blocks along the roadline indicating settlement, the road down to Water Row (but no buildings along the street) and a simplified line of the burn. He depicts some of the jetties along the banks of the Clyde, but only as far up-river as the Kelvin. His 'Northern Part of Lanarkshire; Southern Part', published in 1821, shows the kirk and manse along with the revised road layout (with buildings lining the sides of Main Street and Main Road), but lacks any further detail and there is no attention paid to alterations made to the river.

A curious addition to the Govan cartographic corpus is a map of the Village of Govan drawn by W.D. Barles in 1906 (Figure 15). This map shows Govan as it was imagined to be in 1837 and supplies detailed information about the occupants and owners of various dwellings and buildings in the village, as well as showing old street names and street layout. The pictographic representations of many of the buildings appear to be fairly accurate. Barle's rendition of the three two-storey buildings at the north end of the west side of Water Row, the dye works and the area around Manse Lane corresponds reasonably well with contemporary illustrations and descriptions. Many of the residents and proprietors listed beside the buildings also appear to be fairly accurate.



Figure 9:

Historic maps: Thomson, 1820.

This is a useful comparative source, but cannot be relied upon, as the origins and purpose of this map are obscure. We know little of how the map was researched and therefore how reliable or accurate it is as source material. It is believed to have been the product of antiquarian studies which were supported by the Old Govan Club, and may also have drawn on the memories of older Govan residents. The date of 1837 may also be telling; such a specific date would suggest the researchers drew on a primary source of this date, perhaps a valuation roll or parish records of births, marriages and deaths.

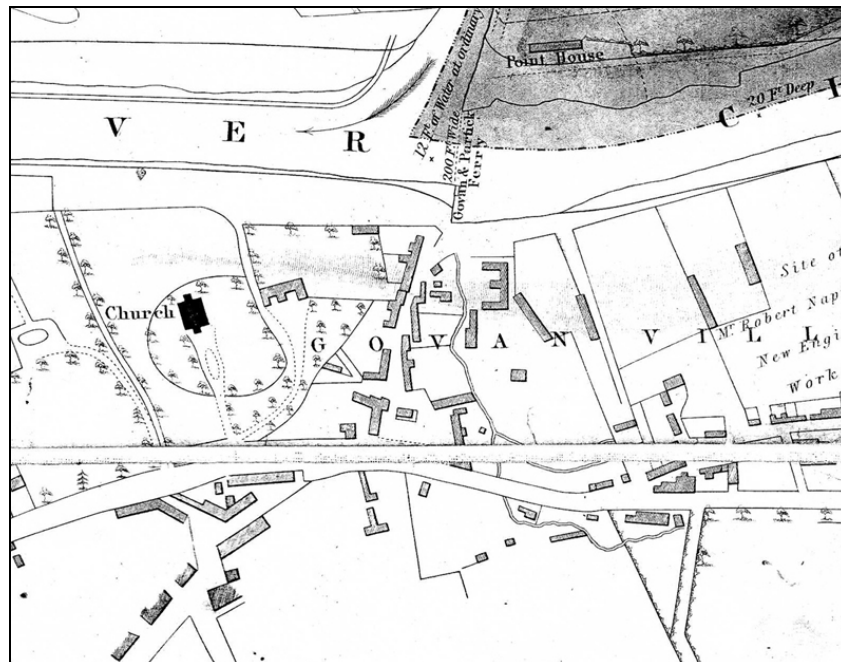

Figure 10:

Extract from George Martin's 'Map of Glasgow published 1842 (Mitchell Library DTC 13/23C-f).

7.1.4 *Martin's Map*

We are fortunate that George Martin's 'Map of the City of Glasgow' (Figure 10), published in 1842, includes Govan, which appears at the western extent of this survey (following the limits of the parliamentary boundary). This map is highly detailed in comparison to previous surveys of the Govan area, and the city-wide survey was used as a source for the Post Office map series by Joseph Swan which first appeared in 1848 (Moore, 1996, 24). It is the first time we see the area around Water Row and the church mapped in detail. When compared against the Ordnance Survey first edition, the map holds up well. Martin has simplified many of the boundary walls (particularly around the churchyard and manse), but the form and location of the main buildings correspond well to those appearing on the OS maps. We are also able to clearly discern individual groups of terraces, such as those that line Water Row; along with a number of large detached houses built within their own gardens that grew up in and around the village during this period, such as Hillock House.

The Gothic Revival church (1826) appears set within the distinctive pear-shaped churchyard. Martin has evened out some of the idiosyncrasies in the line of the churchyard wall to the north-west and south but, on the whole, his depiction remains true to the line of the wall. The area between the churchyard and the riverbank is clear of buildings or trees, but appears to be bounded by a wall which extends from the north-east corner of the churchyard and curves around to the west and follows the line of the riverbank to the junction of the boundary marking the edge of the Govandale estate. The manse is shown to the east of the church, close by the churchyard wall. In plan it is an E-shaped, east/west aligned block set within a large tree-lined enclosure which backs on to the rear of buildings fronting on to Water Row to the east. Access to the manse is via a trackway leading from Main Street which curves around the side of the churchyard. The boundary between the front garden of the manse and property boundaries to the rear of Manse Lane and Water Row is much simplified when compared with the OS first edition. This boundary wall severs the historic link between the churchyard and Manse Lane, although the OS first edition 1:500 survey shows a gate within this wall which would have allowed access via the manse gardens.

Martin's map also shows the south side of Manse Lane as it opens out onto Water Row, defined by an obtusely angled block creating the distinctive splayed form, designed to funnel traffic towards Govan Old Church. This block is all that defines the south side of the lane and there is no depiction of the north side of Manse Lane. This is broadly similar to that shown on the OS first edition, comprising a right-angled block of buildings that line Water Row and Manse Lanes with a wedge-shaped boundary extending from the west end of these buildings and terminating at the boundary around the manse gardens. A long, rectangular block is shown set within this wedge, butting up against the southern manse boundary wall, on approximately the same alignment as the block defining the southern side of Manse Lane. The area to the south of this wedge and to the west of the buildings on the southern side of the lane is open ground.

Contemporary illustrations and pre-demolition photographs of the western side of Water Row show a mixture of one- and two-storey buildings, some facing onto and others presenting their gable ends to Water Row. This irregular layout is captured in reasonable detail by Martin, who makes some effort to show the individual blocks of buildings and the idiosyncratic plan forms which resulted from the way the row evolved.

North of Manse Lane, there is a gap of approximately 20 metres in the line of buildings fronting onto the west side of Water Row; beyond this, two blocks are shown joined together and aligned slightly towards the east in comparison to the buildings to the south on this side of the road. Towards the north end of the row, Martin shows a structure projecting west midway along the most northerly block. Although this building is shown as part of the main block, its location suggests it may be the large outbuilding shown at the rear of the Ferry Inn on the OS first edition. To the north-west of this block, a rectangular structure occupies the north-east corner of the enclosure. This may be the same single-storey building which appears on an undated and uncredited illustration reproduced by MacGeorge (1880), shown partially hidden among the trees behind the buildings at the north end of Water Row.

The eastern side of Water Row is characterised by the same haphazard arrangement of linear blocks of buildings. The two main blocks, situated equidistant from the Govan Road and the river, are on a slightly different alignment from the buildings on the west side of the row, the southern end of the north block being particularly skewed to the west. Comparison with the OS first edition shows that while there is a discernable curvature to the eastern side of Water Row, Martin has exaggerated this alignment greatly. Martin has also chosen to show these rows as separate blocks, where the OS first edition depicts a continuous line of conjoined buildings. Several smaller structures located in the gardens or enclosed backlands to the rear of these properties are absent from Martin's map. At the south end of the eastern

side of Water Row, the road opens out onto an irregular square-like area, open to the south with the Parish School situated in the centre. The northern side of the square is defined by a boundary wall and a long, roughly east/west aligned rectangular block, which terminates at the edge of the burn. A Z-shaped block of structures defines the eastern side of this square.

To the rear of properties along the eastern side of Water Row runs a sinuous burn. When viewed in plan, these buildings appear to mimic the curving line of the burn. The burn, possibly the ‘water’ of Water Row, crosses Govan Road to the east of Water Row where it meets a small tributary flowing from the east, to the rear of the Z-shaped structure. This tributary is not shown on any other maps and was culverted or removed to make way for Hillock House, which is first shown on the OS first edition. From the confluence the burn makes its way to the river, with a predominant westward bend midway along its length. This kink corresponds to a bend shown on Roy’s map, though it is less pronounced on Martin’s map. The burn meets the river Clyde just to the east of the ferry slip. The stability of the form of the burn from the mid-eighteenth to the mid-nineteenth century is critical for consideration of the location of the Doomster Hill (see below).

Several large buildings are dotted around the eastern side of the burn, contained within what appears to be a property boundary. William Simpson’s watercolour view of ‘Napiers Building Yard’, dating to 1845, shows these boundaries clearly, along with the southern end of the reverse E-shaped building shown on Martin’s map. This building, along with a north/south aligned block positioned to the south-west, close to the burn, and a further square-shaped block in the centre of the property, are likely to be part of Reid’s Dye Works, which occupied the site from the early 1800s until the 1860s-70s. The ‘Napiers yard’ referred to in the title of the illustration was Robert Napier’s Old Govan shipyard, founded in 1839 by MacArthur and Alexander. At the time of Martin’s map and Simpson’s watercolour, the yard occupied the property adjacent to the dye works, but it later acquired the dye works site and expanded its operation into this area.

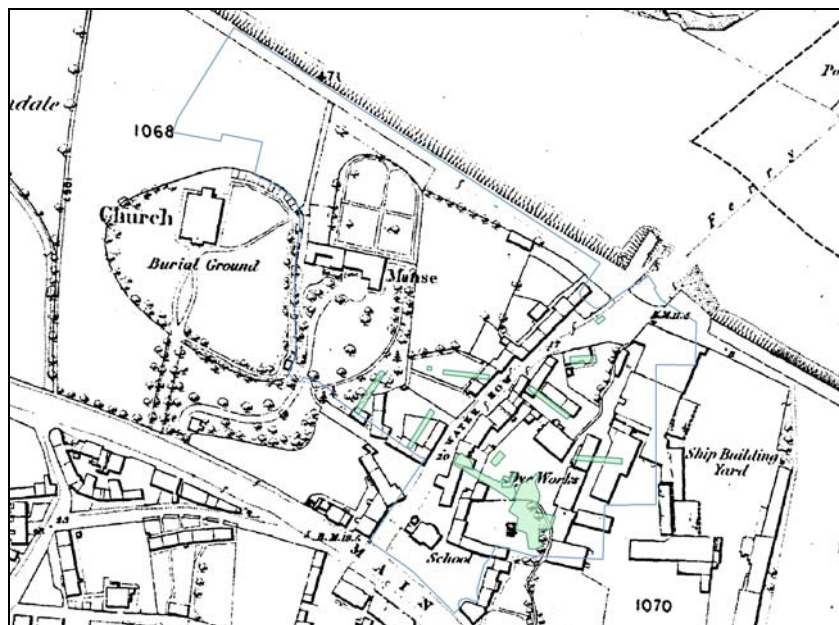

Figure 11:

Ordnance Survey first edition 1:2500 (1856-58).

7.2 Ordnance Survey Mapping (Figures 11-14)

The Ordnance Survey first edition surveys, conducted between 1857 and 1858, were published at 1:10,560 and 1:2500, but the OS also produced a more detailed series of maps at 1:500 (commonly known as Town Plans). These first edition maps show Govan at the outset of industrialisation, and the Town Plan in particular provides an unprecedented level of detail. However, the Ordnance Survey maps were produced for specific purposes and so lack detail in some areas. Sanitation was a main concern of the first edition surveyors and the maps are good at defining water courses and identifying specific industries and even particular buildings within a works and other water supply details. House plans are less well defined, often

making it difficult to distinguish between different housing types. Further surveys were conducted in 1893-4 (OS second edition), 1913 (OS third edition) and 1933 (OS fourth edition), which are invaluable for charting the change, but given the pace of development in Govan these snapshot' inevitably miss some of the changes. Unfortunately, only the second edition surveys included a 1:500 series, although the 1:2500 scale maps still provide a significant amount of detail.

For clarity, the discussion of the Ordnance Survey maps provided below is linked into the zones applied to the study area for the archaeological work (Figure 1). They are broadly defined as follows:

- Zone A: the eastern side of Water Row, the ferry area, burn and dye works/shipyard areas.
- Zone B: the western side of Water Row and area to the rear abutting the glebe lands.
- Zone C: the area around the north side of Manse Lane and west side of Water Row.
- Zone D: the area immediately to the north and east of the churchyard wall, defined by the river and the limits of the glebe lands shown on the OS first edition.

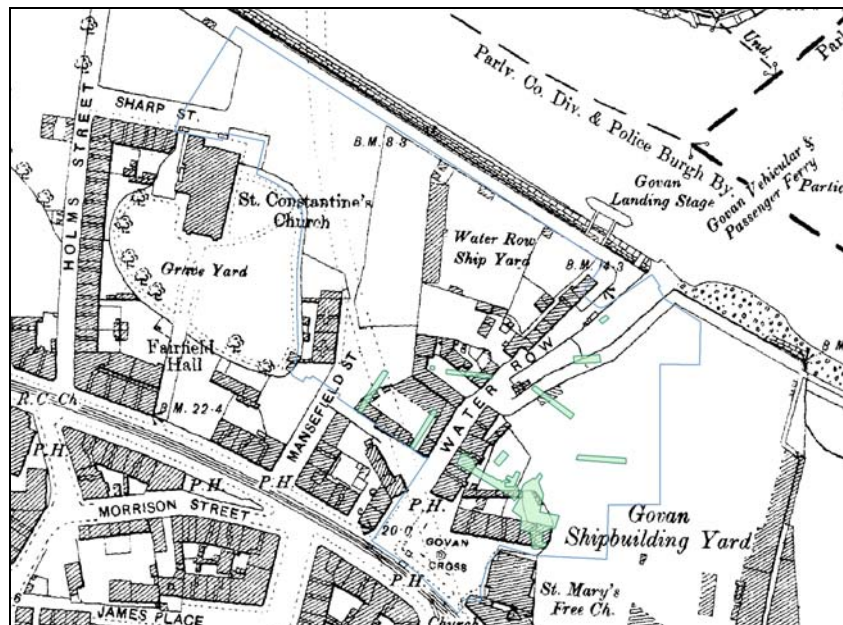

Figure 12:

Ordnance Survey second edition 1:2500 (1895-96).

7.2.1 Zone A

At the north end of this zone, the first edition shows the area around the ferry as comprising a recessed slipway with a small jetty or pier projecting into the river on the west side. By the second edition survey, the ferry area has been significantly re-developed. The projecting jetty is gone, walls have been constructed on either side of the slipway and a set of stairs leading down to the water is shown on the west side. The slipway itself has been extended back up Water Row by c 30 m from the inland edge of the slip shown on the first edition. The river frontage on the western side of the slip is shown as stone-built, with another set of steps leading down to the Clyde at the western corner of the slipway. Just along from these steps, a new landing stage has been constructed. There is no indication of major change to this arrangement shown on the third edition map, apart from the insertion of two linear features – grooves or tracks to aid the movement of carts – into the surface of the slipway. The fourth edition shows a new jetty for a double level vehicular ferry to the east of the old slipway.

The first edition depiction of the buildings lining the eastern side of Water Row shows a much more complex arrangement than Martin's representation, which differs significantly in terms of layout and orientation. Martin shows two main blocks of buildings lining the edge of the street. The first edition shows these structures as a continuous line of buildings, composed of blocks set at slightly irregular angles to one another. On the lower reach of the burn, the backlands and gardens run down to it. The middle section of the burn is dominated by Reid's Dye Works, which have introduced new buildings on both

sides of it, including a large squarish building over or on the edge of the burn. The western bend in the burn is no longer visible, because the middle stretch has been culverted. Where it remains open, the tree-lined course of the burn is visible, but the lower stretch which exits north of the squarish dye works building has clearly been canalised and straightened. It still discharges on the eastern edge of the slipway, apparently via slipway itself.

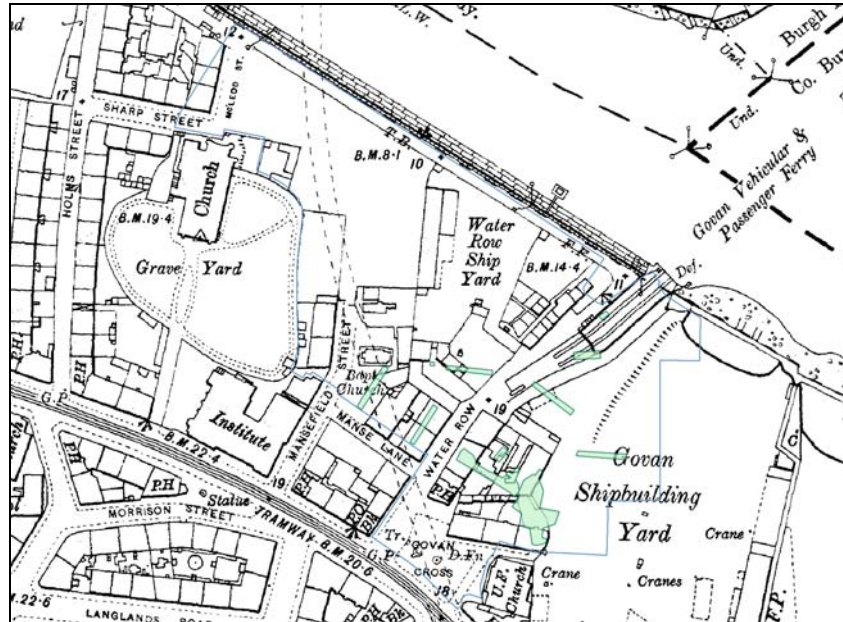

Figure 13:

Ordnance Survey third edition 1:2500 (1905-10).

The dye works grew dramatically between Martin's 1842 map and the appearance of the OS first edition. The E-shaped block at the north-east end of the site was replaced or incorporated within a much larger series of buildings that stretch from the Clyde back towards the Govan Road to the southern extent of the study area. The importance of water for the dyeing process is evident in the proximity of the works to the burn and in its canalisation, culverting and straightening. The degree to which the course of the burn has been modified is another critical issue for locating the site of the Doomster Hill. Central to any consideration of its location is the account of the insertion of a reservoir into the hill (see above and below). One possibility is that the curving line of five trees visible below the legend 'Dye Works' and the double-walled boundary containing the burn defines the eastern extent of the Doomster Hill. The small isolated square structure to the west could on this reading be the reservoir. This is where the bulk of the archaeological investigation took place and where the massive ditch was excavated (Section 8.0).

The southern end of Water Row opens out into a square defined by a series of blocks, slightly set back from the main alignment of buildings fronting onto Water Row. In the centre of this public space stands the parish school, built in 1800 (Brotchie 1837, 234). On Martin's map, there is a gap in the north-east side of the square, but by the time of the first edition this has been filled with another north/south aligned block and the existing range defining the northern side of the square had been modified. The burn defines the eastern extent of the backlands of the properties ranged along the eastern side of the square. This boundary remains on all subsequent OS map editions, even after the burn has been fully culverted sometime between first and second editions (when it was replaced by a wall).

The second edition surveys show a radical change to the east side of Water Row. By this time the dye works have been cleared and the property taken over by the 'Govan Shipbuilding Yard', but no structures are shown within the central study area, apart from a solitary rectangular block at the end of the ferry slipway. Presumably the work was undertaken using the traditional temporary timber scaffolding, which were reorganised as need dictated. All trace of the burn has been completely removed and it has presumably been culverted below the ground surface. The ragged line of buildings that fronted on to Water Row has been entirely removed at the north end of the road and the buildings to the south have been replaced with a block of three tenements, with a public house at the south corner block. The

east/west aligned buildings that defined the north edge of the square have also been replaced with a tenement block, positioned on approximately the same alignment. (These tenements were noted in the excavations.) The tenements have associated back courts and outbuildings to the rear; the corner building was occupied by a 'Bank' on the 1:500 scale map. The dwellings on the east side of the square were replaced by St Mary's Free Church and hall, which still stands today.

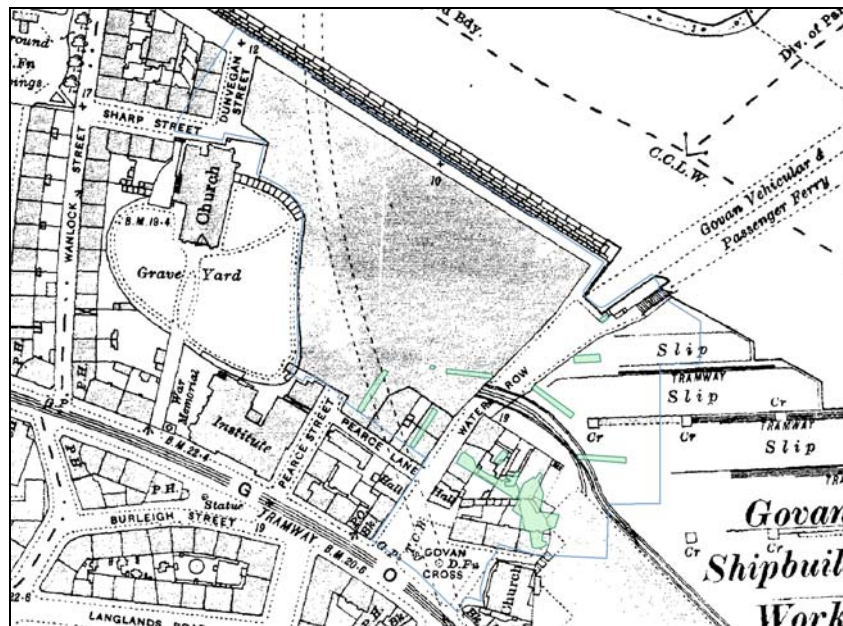

Figure 14:

Ordnance Survey fourth edition 1:2500 (1938-39).

The parish school, which occupied the centre of the square, was demolished in 1874 and by the 1890s the site is given over to a large drinking fountain set on a hexagonal plinth. The square retains its status as a public area, but has been re-designed as a social space, with the fountain as the central focus surrounded by seats. This is the first cartographic source to annotate this area as 'Govan Cross'.

The third edition map shows little change in this area, apart from an extension to the property boundary to the rear of the tenement block fronting on to Water Row and the addition of a few small structures within this enclosure. The burn has been fully culverted and possibly diverted, but a wall at the rear of the properties on the eastern side of Govan Cross preserves the line of the burn. Entrance steps down into underground public toilets can be seen to the west of the fountain. The northern portion of the zone is still occupied by the 'Govan Shipbuilding Yard', and is still free of structures at the time of the survey. In 1912, this area was bought over by Harland and Wolff and development was radically accelerated. By the fourth edition, we see several large slipways, aligned ENE/WSW, running back from the river's edge. Tramways line the southern edge of the slips, along with several large cranes. A series of train tracks connect the slipways and works in the western Harland and Wolff premises with the shed across the road on the eastern side of Water Row.

A plan of the area in and around the Harland and Wolff yard (Mitchell Library, TCN 19/267), produced in advance of construction work in 1913, shows the buildings at the south end of the zone as a mix of dwelling houses and business premises, including a funeral home and hiring company. The buildings to the rear of the tenement blocks are annotated as offices, sheds and stables.

7.2.2 Zone B

On the first edition maps, the buildings at the north end of Water Row are very similar in form to those shown on Martin's map, but these is a much greater degree of detail. Individual properties are indicated and the gardens and backlands more carefully defined. The most northerly property has an enclosed front yard projecting into Water Row and along the river front. To the west of the backlands is a large, rectangular, tree-lined enclosure. Martin's map does not show this division, which implies this area was part of the kirk glebe lands. However, the OS first edition shows this area as a separate entity and the

eastern extent of the glebe lands is shown as bounded by the north/south wall which encloses the manse gardens. The OS depiction is supported by a 'Plan and Section of the south bank at Govan' dated to 1859 (Mitchell Library, Glasgow; ref. TCN 14/249), which marks the area to the west of the enclosure as part of the 'The Minister's Glebe of the Parish of Govan'. The small rectangular building occupying the north-east corner of the enclosed field (which is also seen on Martin's map) remains, but by the time of the second edition it has been removed by the shipyards.

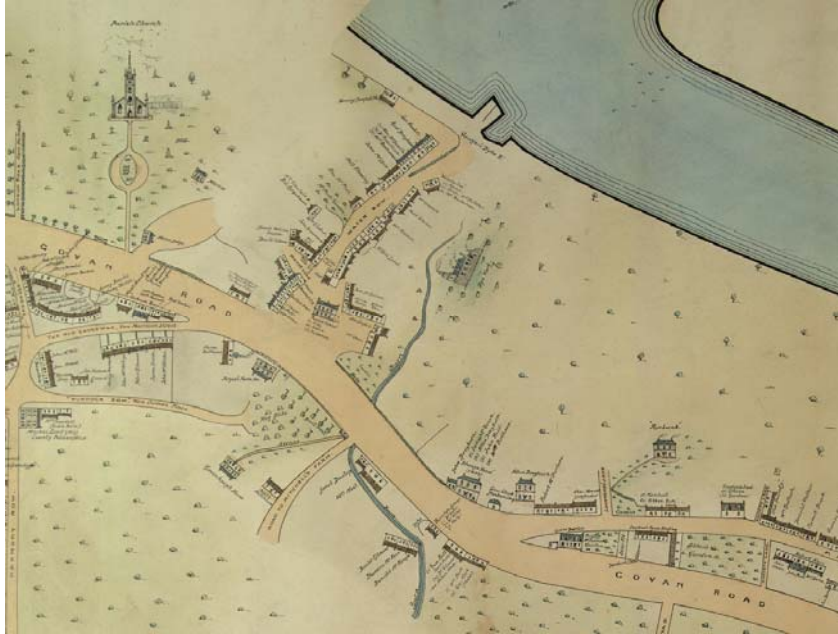

Figure 15:

Map of the Village of Govan drawn by W D Barles in 1906 (Govan Reminiscence Group).

Almost a third of the southern end of the block facing on to Water Row, up to and including the building that faced gable-end onto the street, has been demolished by the time of the second edition. The remaining portion retained their backlands and structures and survived until around 1911, when they were demolished to make way for the Harland & Wolff shipyard. The fourth edition shows this area, and the area defined as zone B, completely occupied by the Harland and Wolff's yard, eradicating all traces of the old western side of Water Row.

7.2.3 Zone C

The area around the corner of Manse Lane and Water Row did not significantly change during the period between Martin's map and the first edition OS. However, we can see much more detail in this area; on the 1:2500 and Town Plan series we can discern individual buildings, and external stair towers to the rear of two buildings at the southern end of Water Row. The first edition maps show a boundary running parallel to buildings on the north side of Manse Lane, extending from the western end of the buildings on Manse Lane and abutting the kirkyard wall. The triangular wedge-shaped area shown on Martin's map, at the western end of Manse Lane on the north side of the road, is more clearly defined on the OS maps. Tacked on to the west end of the right-angled block that sits at the corner of Water Row, a rectangular block with its gable end facing onto Manse Lane runs north/south up to the church glebe boundary wall. West of this is a single, square-shaped block which also butts up against the glebe wall. At this point the wall turns sharply to the north-west and follows the line of Manse Lane for a short stretch up to the gate into the grounds of the manse. It seems likely that this peculiar triangular set of buildings marked the original approach to the manse prior to the post-1826 reorientation of the church to the Govan Road.

The gap in the line of buildings fronting on to Water Row, shown on Martin's map, is now partially blocked by a boundary enclosing an area free of buildings which extends west up to the glebe wall. The narrowed gap in the street frontage provides access to an open area at the rear of properties on Manse Lane and Water Row, with a small shed or outhouse sited in the north-western corner. To the north, a narrow path separates this enclosed area from the north block of buildings on Water Row.

The removal of the manse in the 1860s began a process of development of the previously open ground. This can clearly be seen on the second edition survey. The north/south oriented block at the east end of Manse Lane has been replaced with buildings facing on to the street. The buildings at the north-west corner of Manse Lane and Water Row was also modified. A new rectangular building of unknown function occupies the north-eastern side of the block. The old wall defining the eastern side of the manse gardens was retained and the gardens developed for shipbuilding and housing. The central stretch of Manse Lane was occupied by a warehouse built in 1904 (Hume, 1974, K17) and tenements fronting on to Water Row, both of which survived the coming of Harland and Wolff. The fourth edition map recognises the relocation of the manse; Manse Lane was renamed 'Pearce Lane' and the shortened Mansefield Street re-named 'Pearce Street'.



Figure 16:

View of Govan waterfront from the east showing fishermen at work in front of their hut on the shore. In the background, part of the Doomster Hill and Reid's dyeworks can be seen to the left of the hut. Part of Water Row is visible to the right (Mitchell Library, Glasgow; EGV 341).

7.2.4 Zone D

Within the study area, the first edition series shows the area to the north and west of the churchyard wall as open ground up to the river. The eastern side of this open area is bounded by a path that skirts around the eastern flank of the churchyard wall, providing an access route down to the river. The Manse and surrounding grounds, shown to the east of the church, are depicted in much more detail than on Martin's map. The manse is shown as a single block, comprising two buildings – a reverse 'L'-shaped building at the east end, with a porch to the south, annotated as 'Manse', and another building joined on to the west which presumably housed the court offices. To the rear, formal gardens are laid out in quadrants and enclosed within a partially tree-lined boundary wall. The eastern boundary wall of the rear gardens, which defines the easternmost extent of the glebe, continues on a north/south alignment towards Manse Lane, where it turns to the west and then curves back round, mirroring the shape of the churchyard wall as it heads towards Govan Road. The area between the manse and Govan Road is populated with patches of dense tree coverage at its edges.

By the time of the second edition series, published in the mid 1890s, the open area to the north of the church is still undeveloped, but has been encroached upon by the construction of the new Govan Old Parish Church. The new church, built in 1888, is a much larger structure than its predecessor and has extended north, punching through the old line of the kirkyard wall. The wall itself has also been remodelled to accommodate the new structure, and a new enclosure has been tacked on to the north of the original wall and surrounds the north end of the church. The second edition also shows the line of the newly constructed subway tunnel, which cuts across the development area at the north-western corner, running under the site of the old manse and continuing to the SSW, under Manse Lane and Govan Cross, and exiting at the south-eastern corner of the site.

The second edition maps show two new street blocks to the east and north of the church, lining the eastern extent of the old glebe lands. The glebe lands were presumably sold off sometime in the period between the two surveys; almost half the old glebe area is now given over to tenement housing. The east end of 'Sharp Street' occupies the far north-western corner of the development area, but at the time of the survey, the north side of the street has been marked out for development, but not yet built upon. This street block is fully occupied by the third edition of 1813, and named as 'McLeod Street' (changed to 'Dunvegan Street' on the fourth edition maps). The second edition shows a series of small buildings occupying a square-shaped enclosure added to the north-eastern side of the churchyard boundary; these were probably outbuildings for use by the assistant minister, who occupied the basement flat in the new church. They have been removed by the Harland and Wolff yard by the time of the fourth edition.



Figure 17;

Extract from Watercolour by William Simpson of the Govan waterfront from the east in 1845. In the middle distance is the fenced Old Yard and, at the water's edge, the ferry slip. Further in the distance, the light-coloured building marks the end of Water Row. The steeple of Govan Old punctuates the skyline. The long building in the foreground is part of Reid's Dye Works. (Mitchell Library, Glasgow; Mitchell ref. – EGV 476).

To the east, the manse and gardens have disappeared, having been demolished in the 1860s to make way for shipyards (Brotchie 1938, 161-162). A new street ('Mansefield Street') runs along the east side of the new Pearce Institute into the former manse gardens. A block of two tenements, complete with back courts abutting the churchyard wall and a small enclosure to the north, were built on the west side of the new street.

The boundary defining the eastern extent of the old glebe lands is retained through the second and third editions before it is consumed within the Harland and Wolff plating shed that completely covered the area by the fourth edition. On the second edition, a long rectangular enclosure extends north-west/south-east to the east of this boundary, but it has gone by the time of the third edition. The third edition shows the tenement block at the north end of Mansefield Street. The enclosure to the north has been extended and remodelled, perhaps marking out a new block of tenements which were never constructed.

The third edition shows the continued growth of Mansefield Street, which has extended north, changing alignment at the junction with Manse Lane to run along a north/south orientation. Opposite the tenement block at the north end of this street lies a small Baptist church, accompanied by buildings which are presumed to be a hall and manse. All these structures have been cleared to make way for the shipyards by the time of the fourth edition.

7.3 *The Course of the River Clyde*

Surveys of the River Clyde start to appear in the late 1700s. Until this point, the shallow depth of the Clyde limited the size of vessel that could navigate to and from Govan and Glasgow. To cope with the increasing demands of trade and industry, a substantial programme of alterations and improvements to the river was undertaken. This included dredging, straightening and widening of the river, as well as the creation and consolidation of retaining walls and embankments along the riverside (Deas 1876; Dalglish & Driscoll forthcoming).



Figure 18:

View along Manse Lane (now Pearce Lane) looking east from Water Row, by J.P. Main, 1870. The buildings on the left, including Moses Waddell's Inn on the corner, are angled to funnel traffic towards Govan Old. The gate in the distance leads through the manse gardens and then into the churchyard (Brotchie 1938).

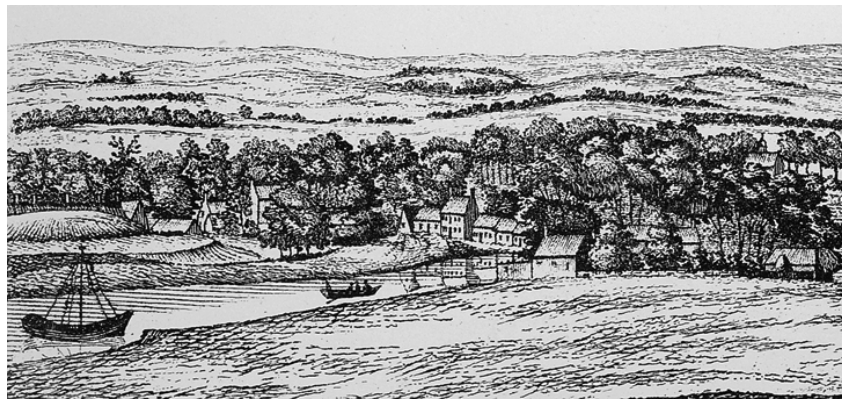

Figure 19:

George Martin's map of 1842, showing location of dye works and possible location of Doomster Hill.

Unfortunately, the majority of these plans do not include suitable reference points to enable them to be compared against modern maps or the Ordnance Survey first edition. Thomas Kyle's 'map of the River Clyde', dating from 1838 (Mitchell Library, Glasgow; ref. FCN 14/10), provides the best opportunity to examine, with a reasonable degree of accuracy, the extent to which the river line has changed. Comparison with the Ordnance Survey first edition shows that the south bank of the river around the Water Row area was consolidated by up to 20 m during the intervening period. A 'Plan and Section of the south bank at Govan', dated to 1859 (Mitchell Library, Glasgow; ref. TCN 14/249), annotates the distance between the rear boundary of the church glebe lands and the edge of the river frontage as '20 feet wide'. The line of the river in the immediate vicinity of Water Row changes little; however, slightly upstream at the east end of the village, the natural bend in the river is significantly straightened out.

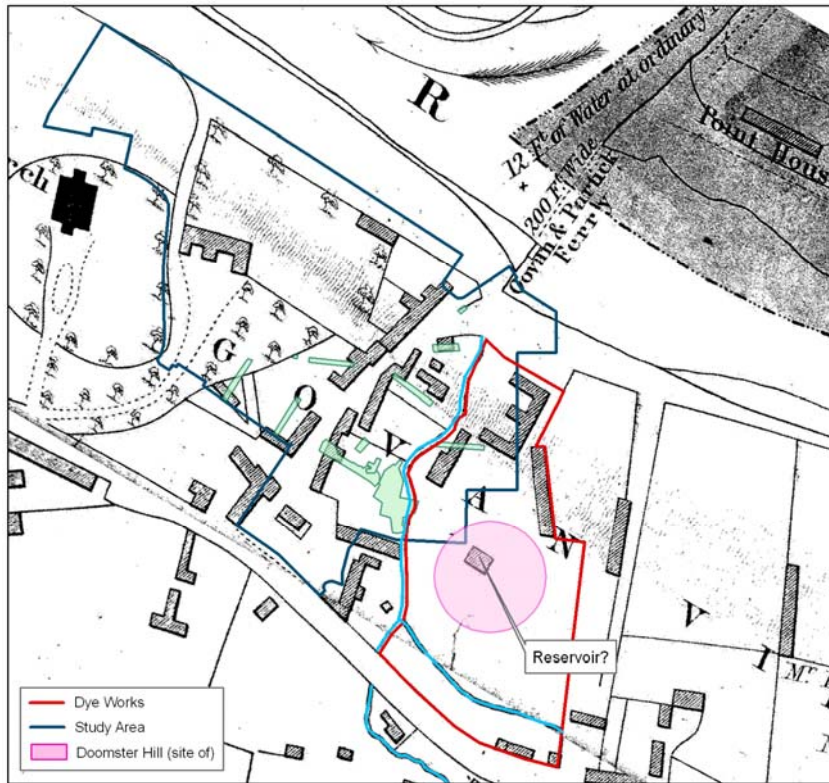

Figure 20:

Ordnance Survey first edition 1:2500 (1856-58), showing expanded dye works, new Hillock House and possible location of Doomster Hill.

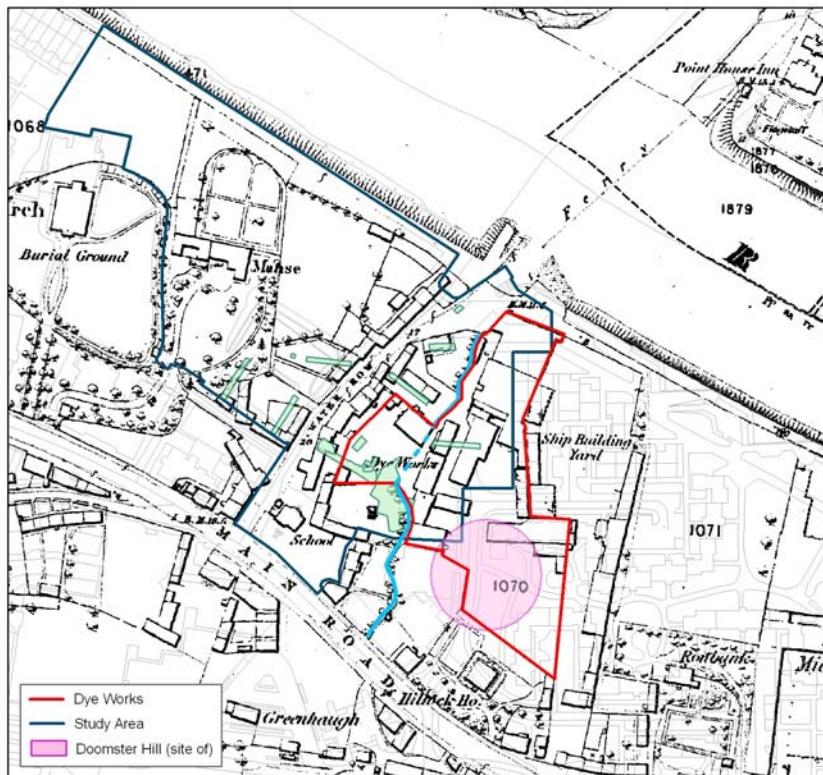
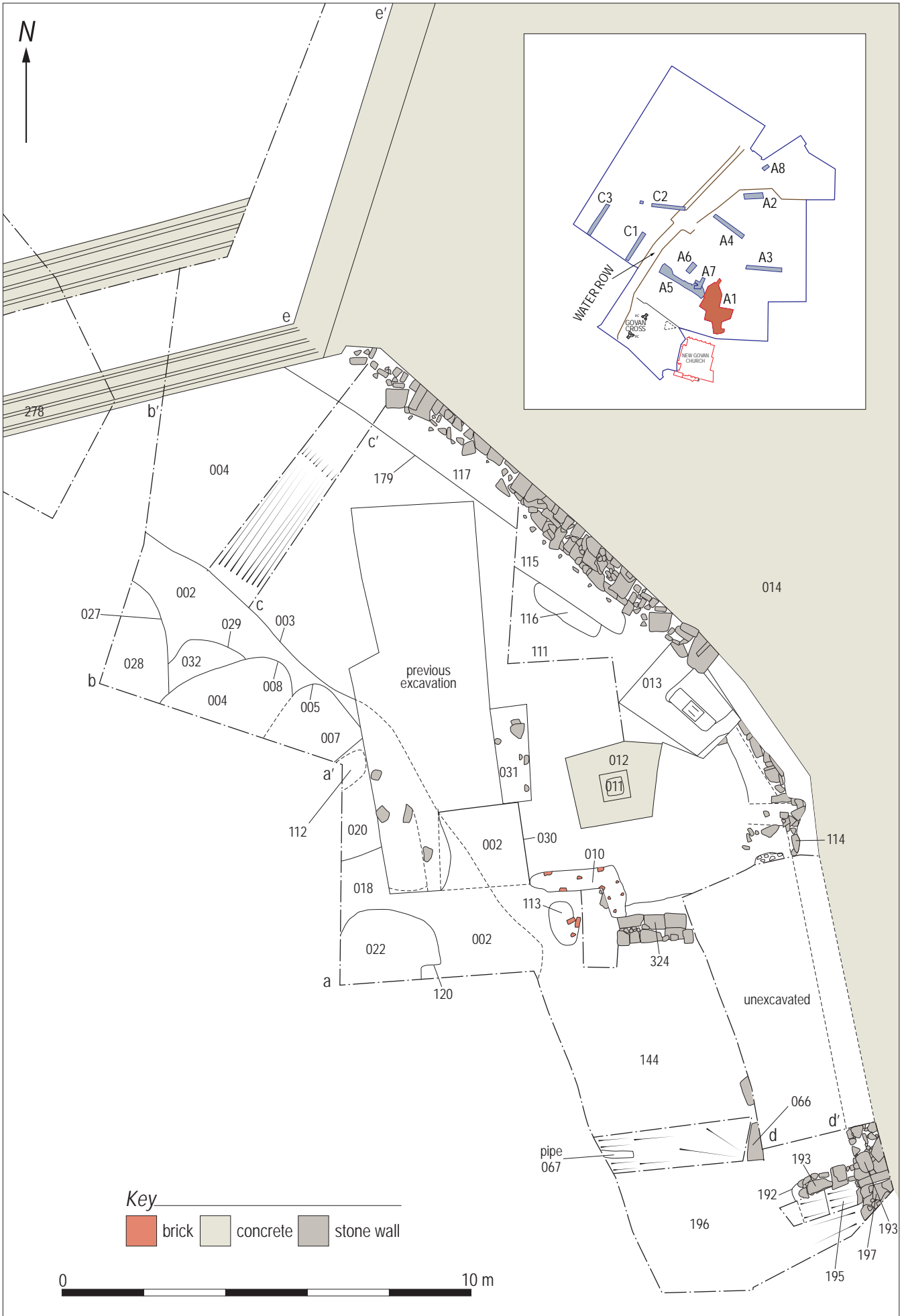
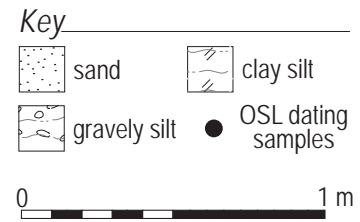
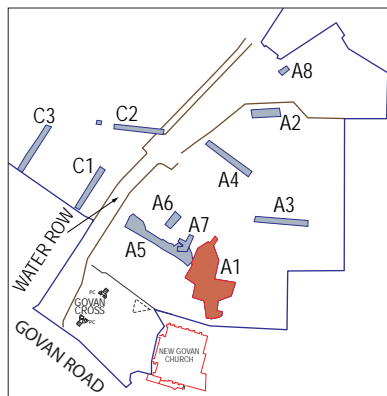
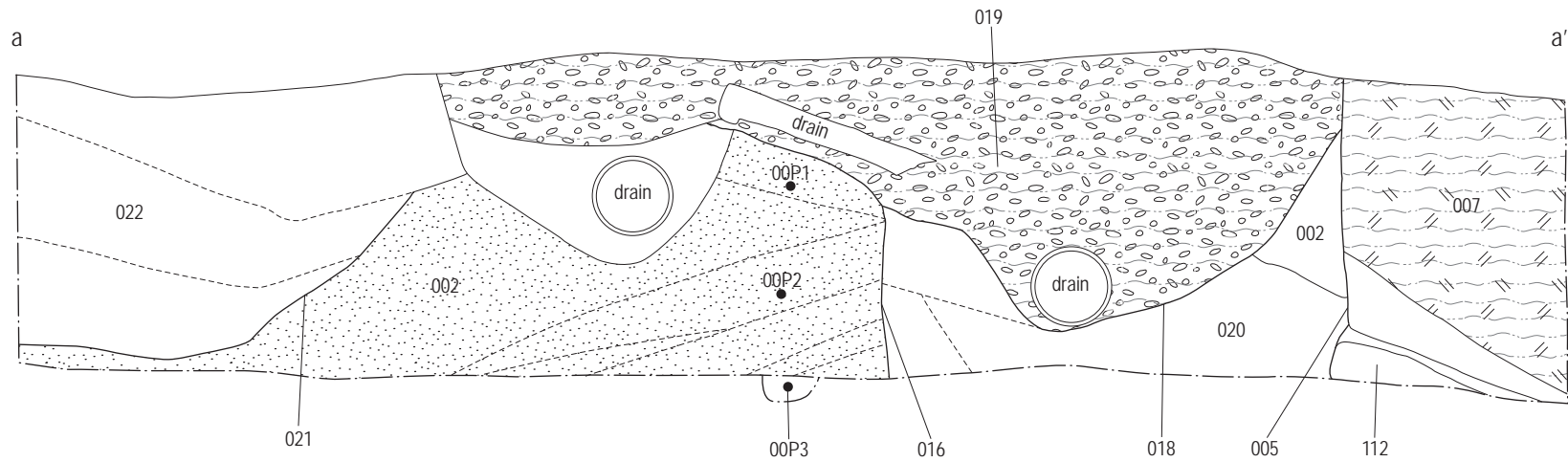
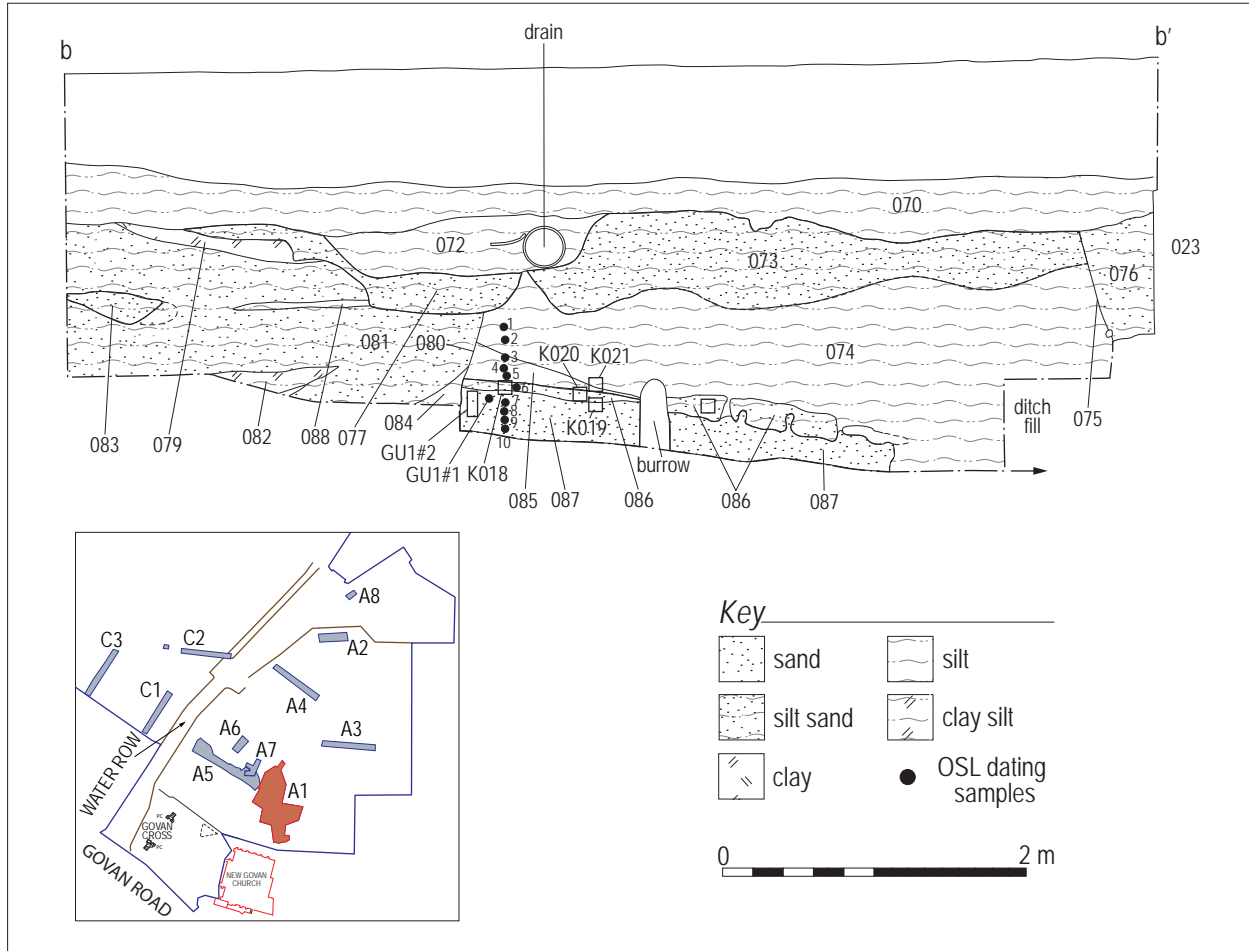

Figure 21:

A view of the banks of the Clyde taken from York Hill' by Robert Paul, 1758. This early illustration shows the Doomster Hill on the far left as a large, stepped mound. Water Row lies east of this. (Mitchell Library, Glasgow; ref. EGV 210).







c

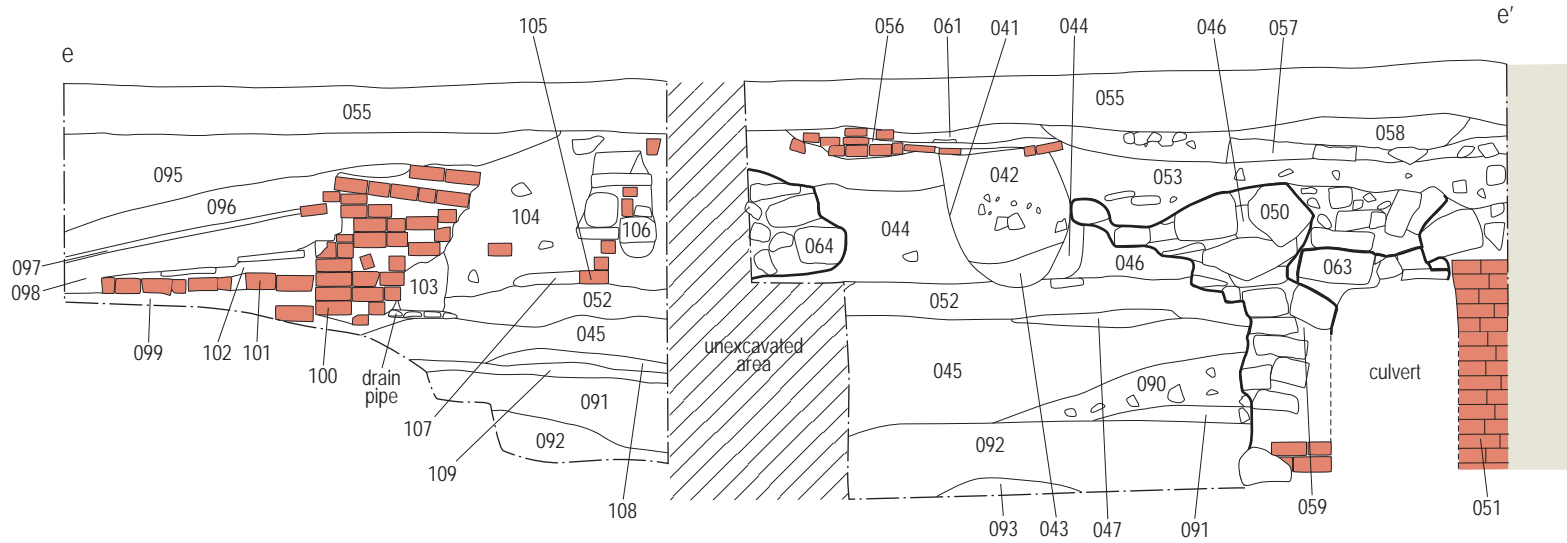
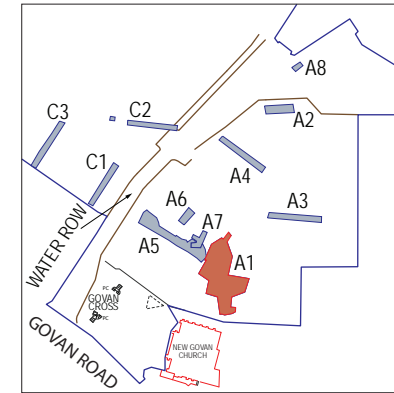
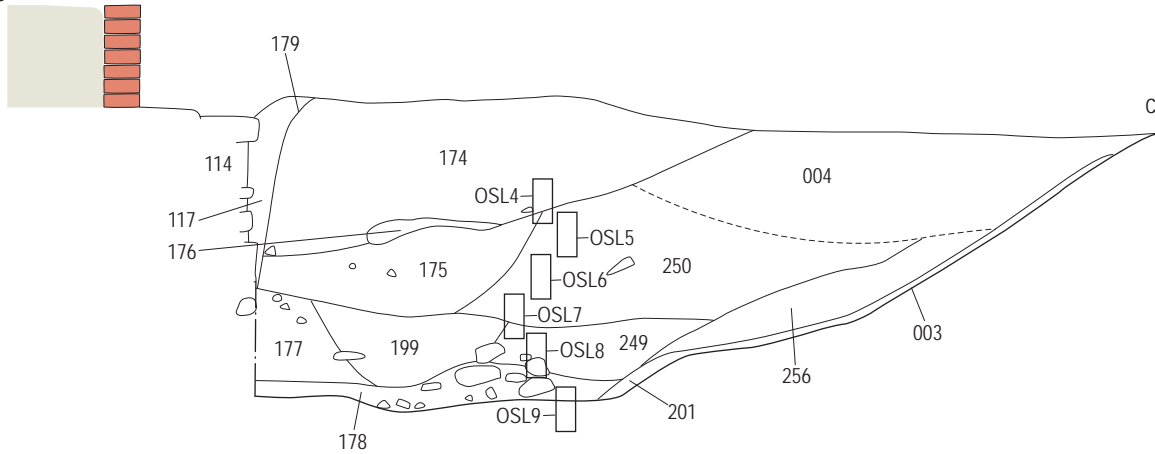

Key



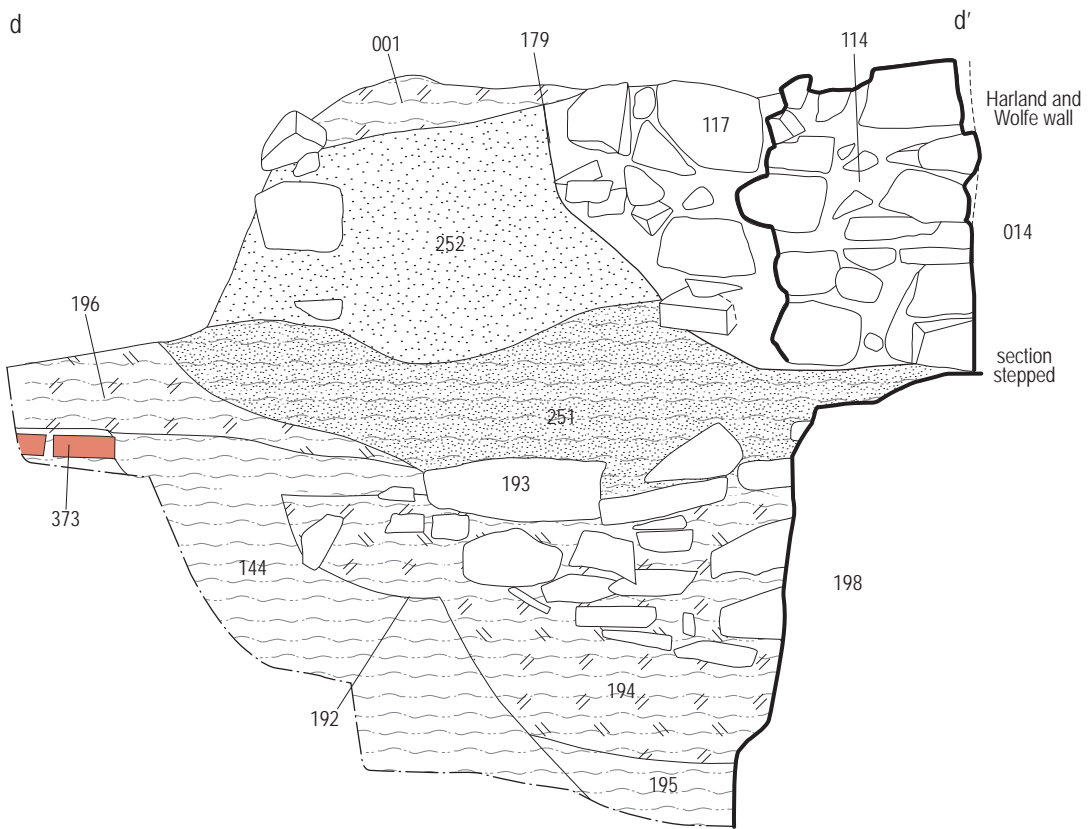
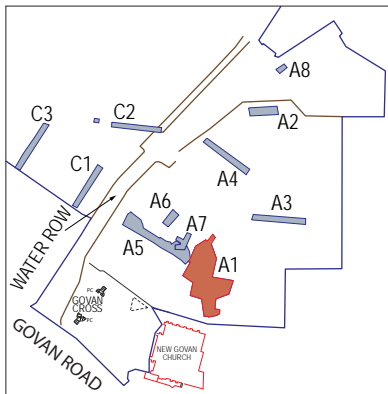

Key

- | | | | | | |
|--|------|--|-----------|--|-------|
| | sand | | clay silt | | brick |
| | silt | | sand silt | | |



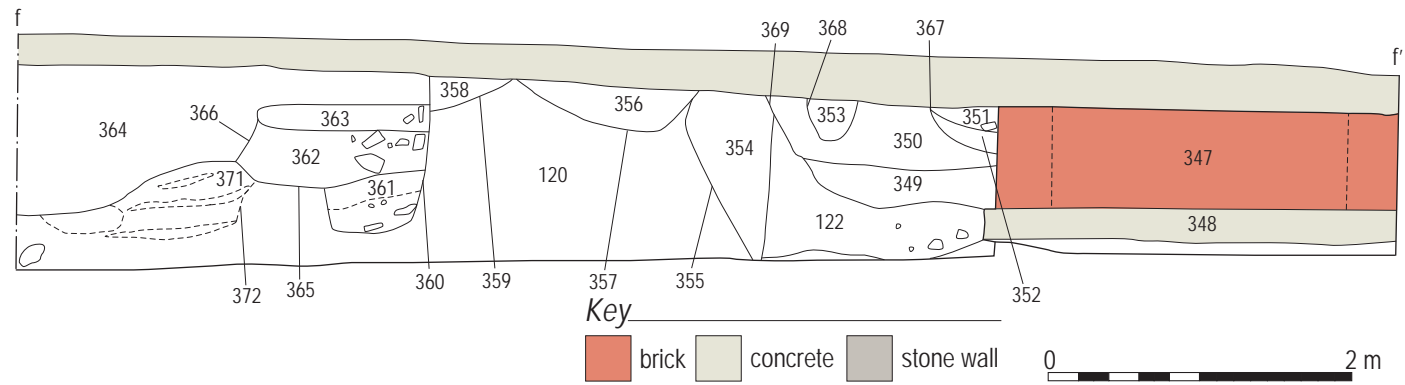
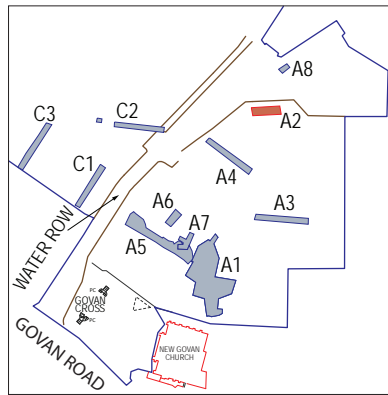
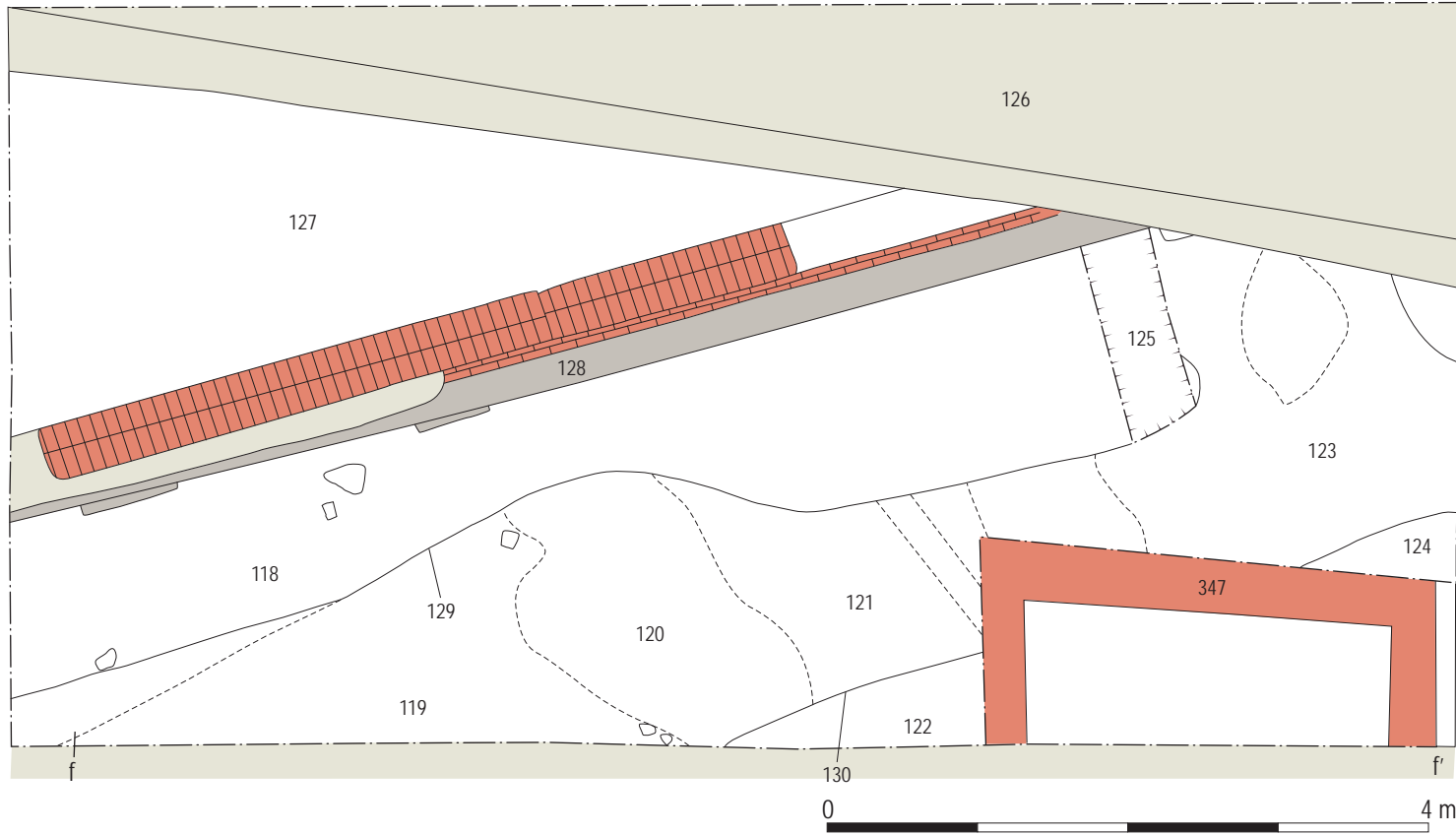

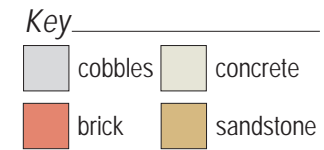
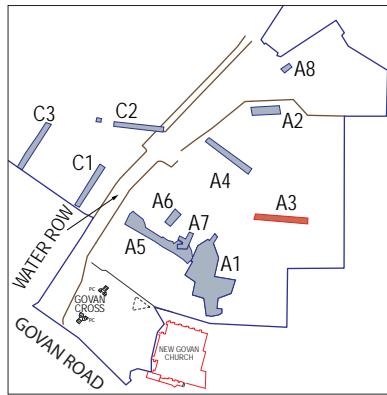
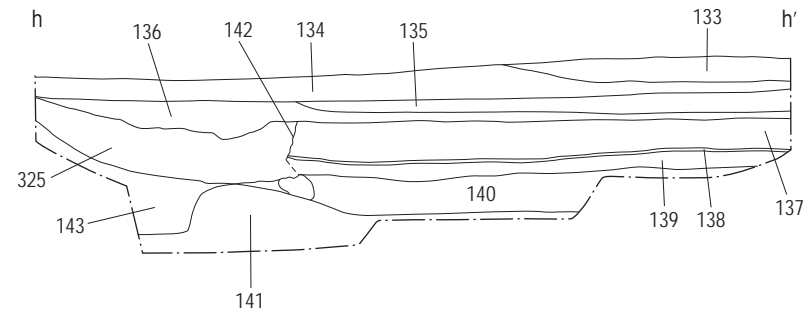
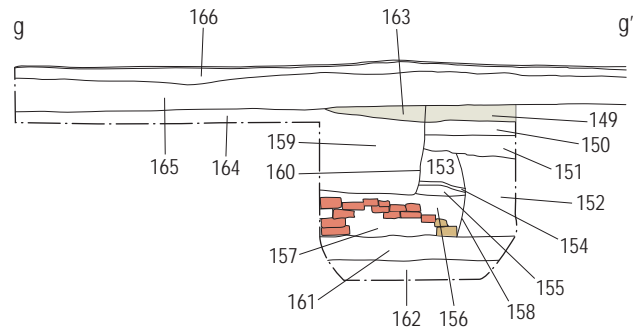
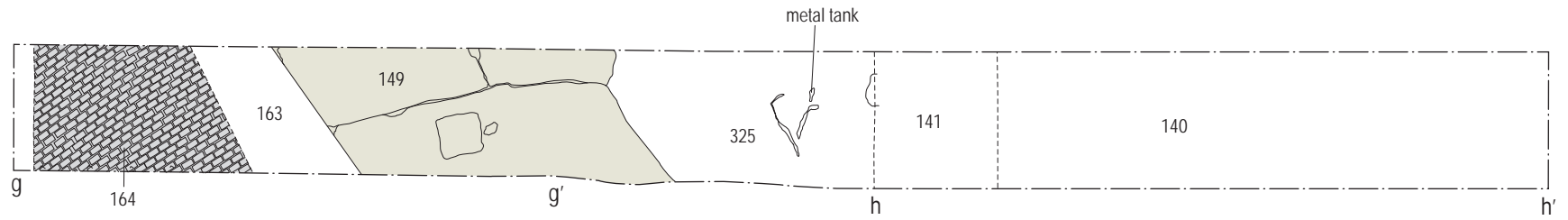

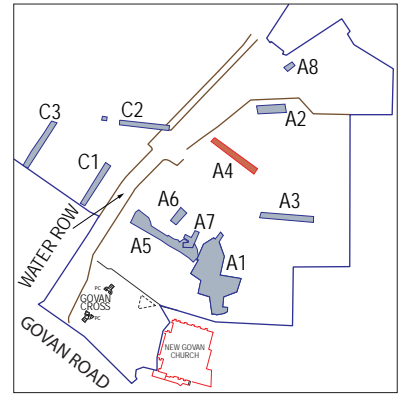
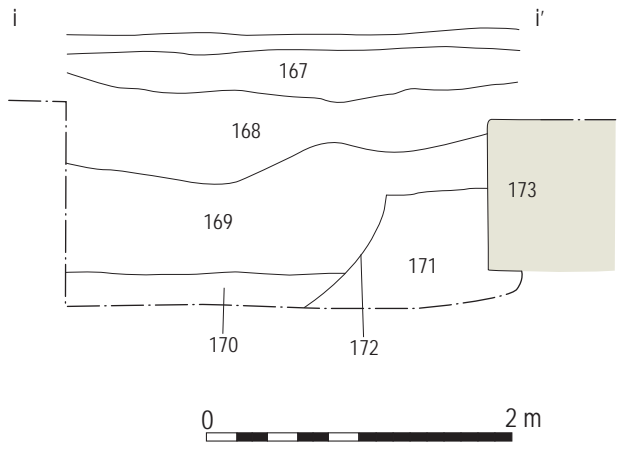
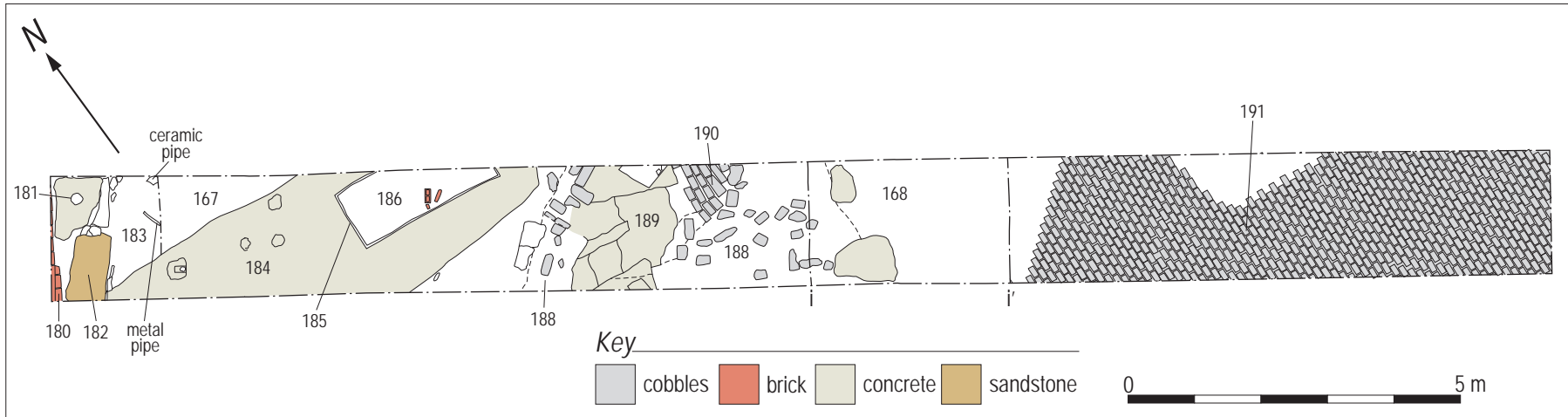

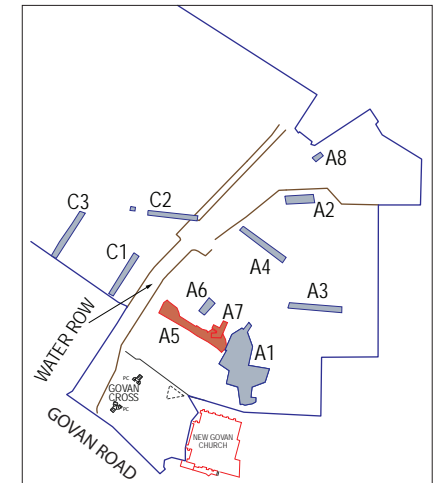
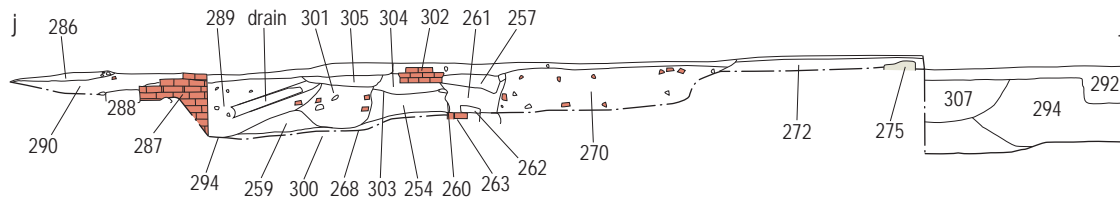
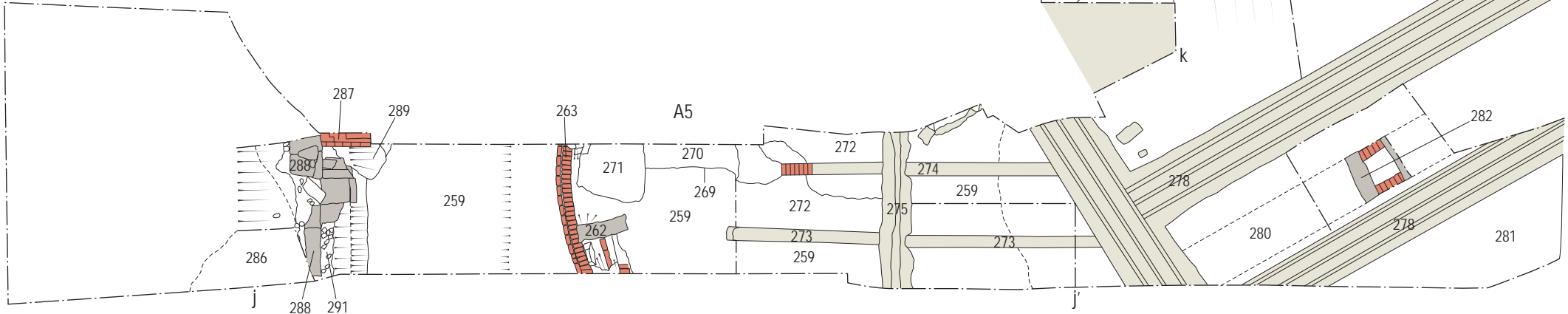
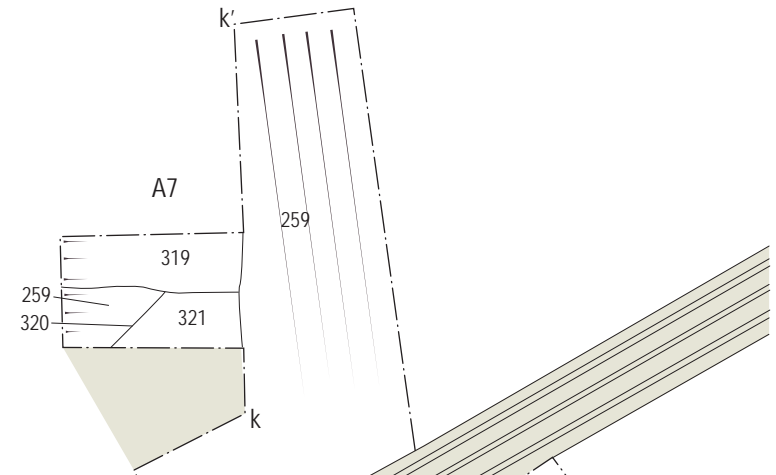
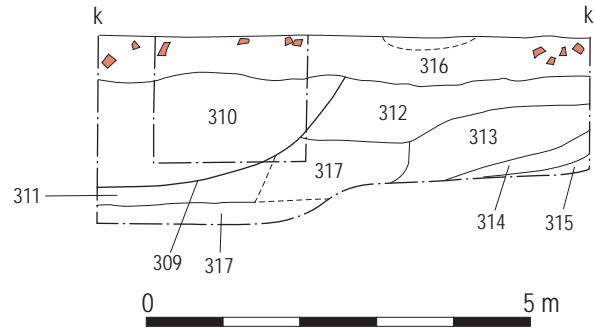
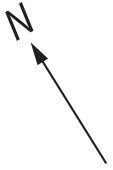

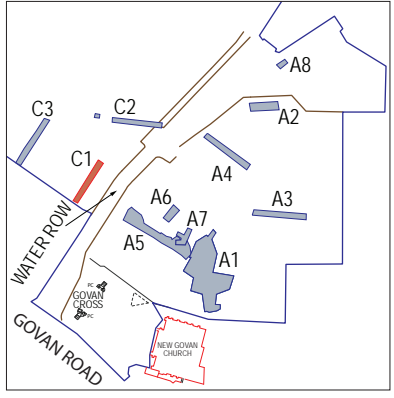
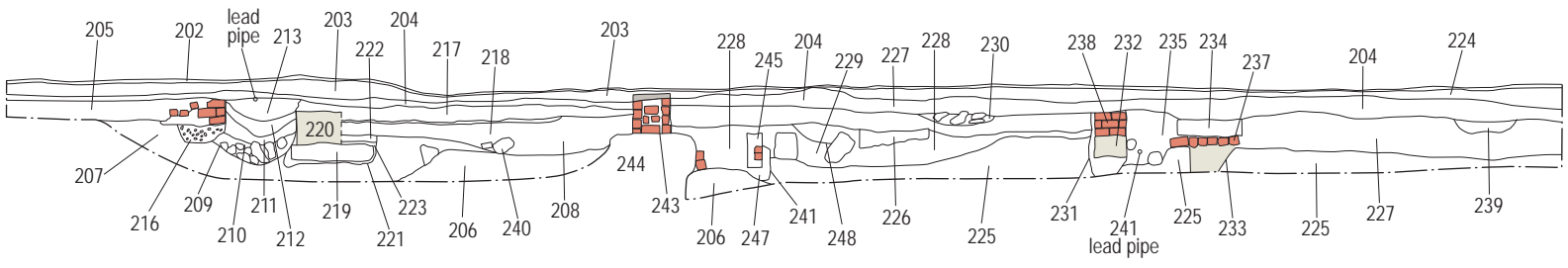
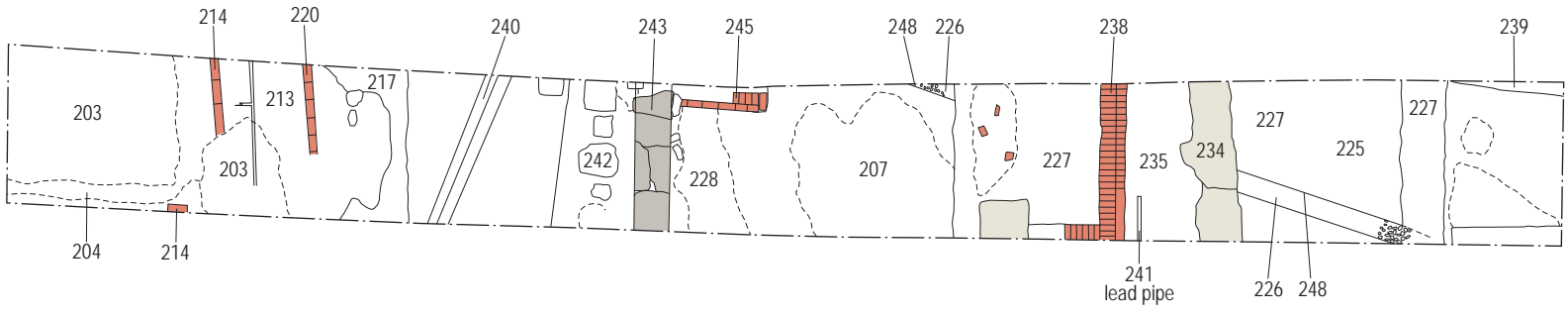

Key

	stone		brick
	concrete		



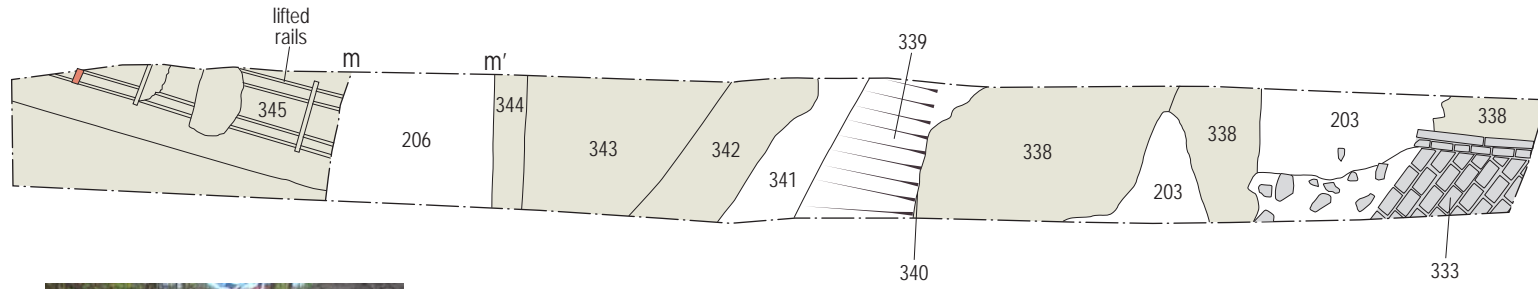





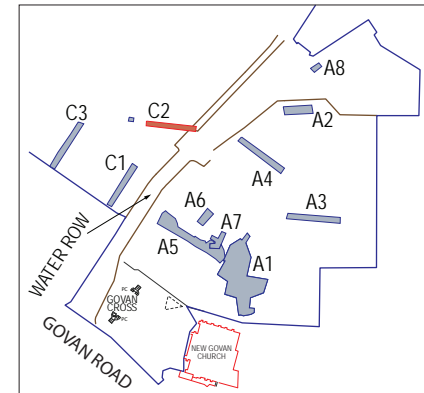
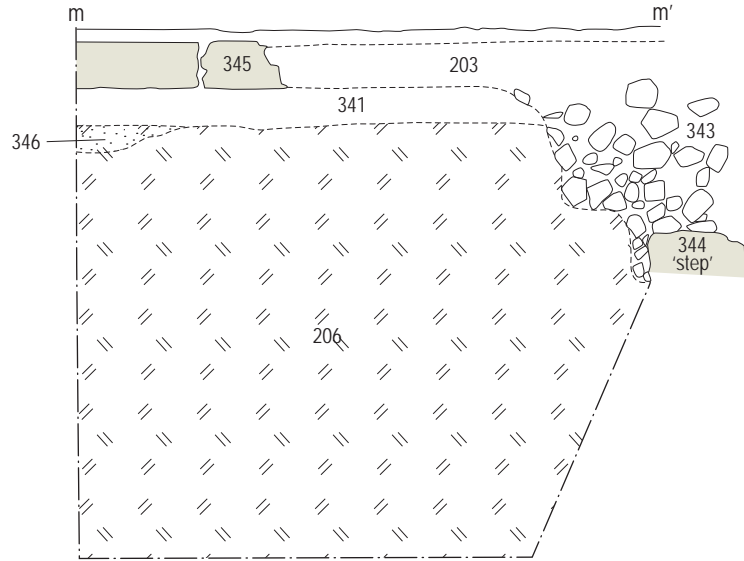

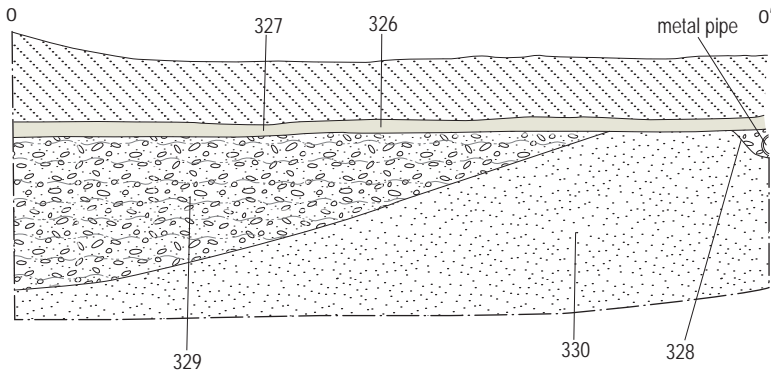
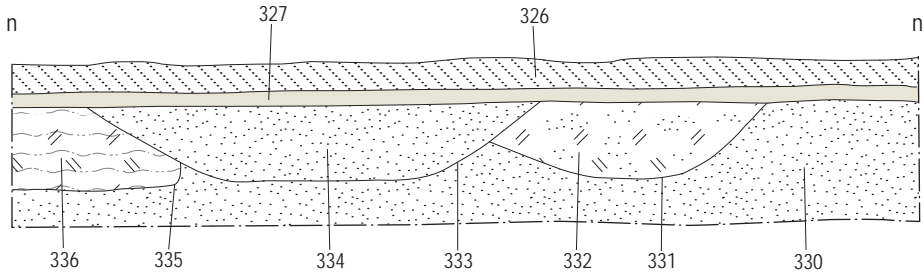
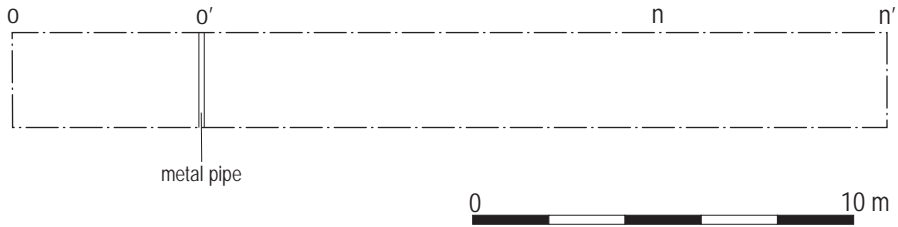
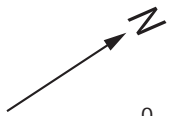
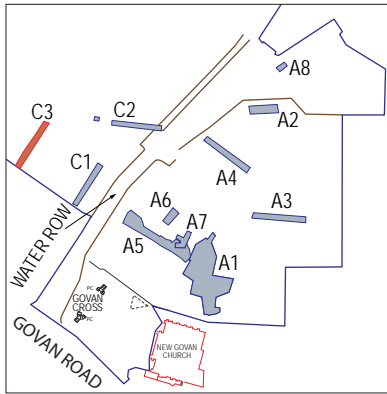
Key

- | | | | |
|--|----------|--|---------|
| | concrete | | cobbles |
| | brick | | clay |
| | sand | | |





Key

-  topsoil
-  concrete
-  sand
-  clay silt
-  silt, sand & gravel



These modifications also removed the small bight to the east of Water Row, first shown by Roy in the 1750s. This shallow bay or beach appears on Kyle's maps of 1838 and 1842, but Martin's map of 1842 shows only a slight indentation in the shoreline at the eastern end. By 1842 only remnants of the bight survived, the remainder perhaps having been straightened out as part of river improvements and the construction of the ferry slipway and pier. This area has been completely re-modelled by the time of the Ordnance Survey first edition of 1857.

Simpson's 1845 watercolour view of the north bank looking upriver (Figure 17) also shows this feature as a fairly deep indentation in the shallow-sloping shoreline. A similar view by an un-named artist (Mitchell Library, Glasgow, ref:EGV 341, Figure 16) shows several fishermen hauling a net towards the shore in this location. This bucolic scene is un-dated, but it shows Reid's Dye Works and possibly the western flank of the Doomster Hill. The Old Govan shipyard, built in 1839, is not shown, and the first reference to the dye works occurs in an advertisement in the *Glasgow Herald* dated to 1822 and reproduced in the *Transactions of Old Govan Club* (1915, 7), providing an indicative date range for the image. It may well be earlier than the 1820s, as the dye works is described as having undergone 'thorough repair' in the *Herald* advertisement. An undated map of property boundaries around the Water Row area (Mitchell Library, Glasgow, ref: TCN/14/39/2) annotates the bay as a 'fishing draught', meaning a place where fishing nets are drawn in (to the shore in this instance), which fits neatly with the illustration. Again, the shoreline is depicted as a gently sloping beach. A small, thatched building which does not appear on map sources is shown set back from the shoreline, perhaps serving as a fishing hut.

The riverbank to the west of Water Row appears to have undergone consolidation work at a slightly earlier date than that to the east. Map sources prior to the Ordnance Survey series give little detail in terms of structural modifications, but the line of the riverbank is suspiciously straight and regular on Kyle's maps of 1838 and 1842 and Martin's map of 1842. A lithograph made by David Allan in the 1830s (Mitchell Library, Glasgow; ref. EGV 249) shows a portion of the bank consisting of a revetted embankment, viewed from the north bank of the river. William Simpson's watercolour also shows a smart, angled waterfront with a fairly large expanse of levelled ground to the rear. The OS first edition 1:2500 map, surveyed in 1857-58, shows the river frontage on either side of Water Row as straight edged, sloping uniformly down to the water's edge. By the time of the second edition survey, undertaken in 1893-94, these presumably earthen banks have been replaced with stone-built structures. A plan of a proposed dyke at Govan Ferry, dated to 1852 (Mitchell Library, TCN 14/234), shows a stone-built wall running along the edge of the riverbank and curving around the western side of the passenger slip at the ferry. Whether these plans were followed is unknown, although there is no indication of a walled structure on the OS first edition surveyed later the same decade.

7.4 *The Location of the Doomster Hill*

From the early 1990s, attempts have been made to identify the location of the Doomster Hill using information from historic maps and archaeological methods (Driscoll and Will 1996, 1997; Dalglish and Driscoll forthcoming), with varying degrees of success. The two small-scale excavations in 1996 identified a deep ditch containing Medieval pottery, which seemed to be in approximately the right location; however, the small scale of the excavations did not reveal enough of the monument to ascertain its position. Also, the dating evidence provided by the Medieval pottery did not suggest a date as old as was expected (ie AD 900 – 1000). Therefore, a main objective of this study has been to locate the Doomster Hill with greater confidence, and this has been achieved. Drawing upon the new archaeological evidence and more detailed examination of the map record, we believe that the Doomster Hill stood to the east of the study area, around modern Napier Street. Given the importance of the Doomster Hill for the heritage of Govan, we examine the evidence at some length here.

The Revd Leishman's entry in the *New Statistical Account* provides a good description of the monument, although the locational information is not precise.

This was the name [Doomster Hill] which was formerly given to a small circular hill on the south side of the Clyde, and immediately opposite the ferry-house. It is supposed to have been one of the law hills of the country. The utilitarian and the antiquary will be differently affected when they learn that a reservoir of the use of the adjoining dye-work has been formed on the top of this tumulus, or hillock, as it is called, in the oldest titles of the property. The depth of the reservoir is about 12 feet. The perpendicular height of the hill itself is about 17 feet, and the diameter of its base about 150 feet

(Leishman 1845, 690).



Plate 1:

Photograph of the nineteenth-century Govan Manse, 1858, from the south (Source: Transactions of the Old Govan Club 1923, Glasgow University Library, Department of Special Collections).

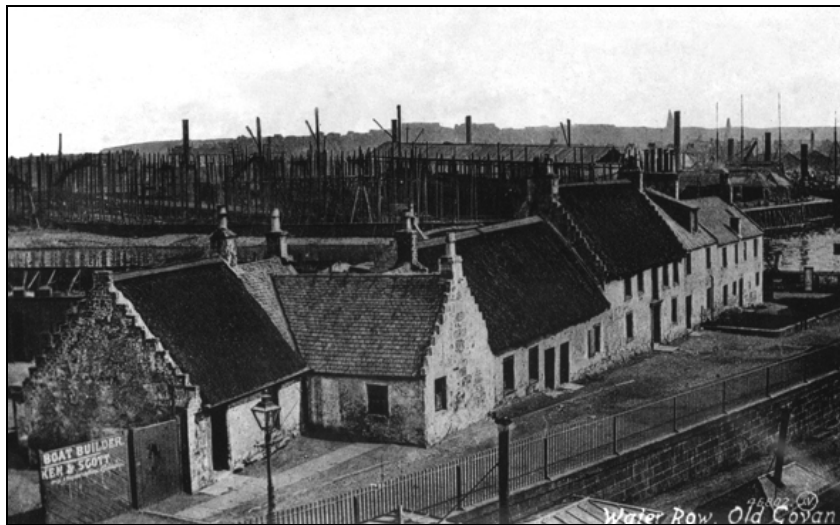

Plate 2:

This high-level view, looking towards the River Clyde, shows Water Row. The two-storey building is the Ferry Inn. A number of shipyards are visible in the background, and the gate to a small boat builder's yard is visible at the bottom left (Mitchell Library, ref. C1750).

The best visual impression is provided in a 'View of the banks of the Clyde taken from York Hill' by Robert Paul (1758), which shows the Doomster Hill as an enormous mound that fills the space between the river and Main Street on the east of Water Row (Figure 20). This engraving reveals two crucial details that are otherwise unknown. It shows that the mound was composed of two levels and that it was surrounded by a ditch, from which the mound had presumably been quarried. Unfortunately, the perspective on this view is skewed, so it is not ideal for locating the mound, although the visible landmarks allow its relative position to be established. The west side of Water Row and ferry area can be

clearly distinguished, with the Old Parish Church shown among trees to the west. The east side of Water Row is more difficult to discern; the gable ends of buildings running perpendicular to the main street alignment can be seen to the east of the mound, but it is impossible to gauge where they are in relation to the rest of the street, which is obscured by trees in the foreground.

The recent availability of digital versions of historic maps has been critical for locating the Doomster Hill, because they can now be geo-referenced to allow them to be compared with precision. The exception to this is the Roy map, which has too many internal contradictions to allow it to be closely linked to the modern map. However, it is not without its value. It suggests that the Doomster Hill might not have been perfectly circular, but more importantly it is the first map to show the hill in relation to the burn. Roy and all the other pre-Ordnance Survey maps show the mound as occupying the area to the east of the burn. This relationship is the key to locating its position.

Roy's map represents the burn with a pronounced crook to the west opposite the mound. While the Doomster Hill may have retained some interest to antiquarians like Leishman in the mid-nineteenth century, surveyors stopped indicating its presence from the 1840s. It is worth noting, however, that neither Martin nor the OS first edition provide any topographic information. The primary purpose of these maps appears to have been to show large houses and estates, street blocks, roads, and property boundaries and other major land divisions; hills and slopes are not represented. The burn also gradually disappeared as it was culverted and straightened. The most detailed representation of the burn is found on Martin's map (Figure 10), which shows two branches flowing from the east and joining as it heads north. It seems that the crook shown by Roy is represented here by the less pronounced bend between the 'V' and 'A' of Govan.

Given the problems with Roy's map, it would be unwise to put too much emphasis on the form of the burn for locating the mound. Nevertheless, the burn is critical. It was utilised and modified by Reid's Dye Works, and it was most likely the expansion and development of the dye works which heralded the demise of the Doomster Hill. The dye works shown on Martin's map consists of four buildings on the east side of the burn – the most conspicuous as an E-shaped one near the river – scattered across the premises. This small-scale works could easily have accommodated the Doomster Hill and even capitalise on its height to provide water pressure; however, by the time of the OS first edition, the works had greatly expanded (Figure 11) and the mound may have become an inconvenience.

Leishman describes the insertion of a reservoir into the Doomster Hill, so the question is can the reservoir be identified? Martin does not name the dye works on his map; it is only by working back from the OS first edition that it is possible to see that the dye works originally were confined to the east of the burn. The legend 'Dye Works' on the OS first edition straddles the burn, because by this time the works had expanded across it, and it was now partially culverted. Unfortunately, none of the dye works buildings are labelled, making identification of the reservoir a challenge. One possible site is a small square building shown to the south of the 'Dye Works' legend on the OS first edition within the gentle curve of the tree-lined burn on the east; this curve corresponds to the line of the ditch excavated in trench A1. However, this must be ruled out, because it is not clear that this parcel of land ever formed part of the dye works or the subsequent shipyard. Moreover, it is on the wrong side of the burn. While it would be possible to have redirected this small burn, the cumulative map evidence does not suggest that it moved a great deal.

Looking to the east of the burn, the mostly likely reservoir is a large squarish building (approximately 10 by 12m) surrounded by open ground, which could comfortably accommodate a mound on the scale of the Doomster Hill. This identification is reinforced by the position of Hillock House, constructed some time between Martin's survey and the OS first edition by the Dreghorn family, who owned the dye works. Leishman reports that the Doomster Hill was known as the 'Hillock' by Govan's inhabitants, and it is labelled as such on Ainlie's map of 1800 (Figure 7). The construction of the house seems to have involved the diversion of the northern branch of the burn, indicating an involvement with water management.

This identification does not allow the position to be precisely located, but it does indicate that the Doomster Hill was located at least 60 m further east than had been previously supposed. This has significant implications for defining the development constraints within the Water Row study area. It does not alter our understanding of the importance of the site for Govan's history and geography; however, it does mean that further archaeological investigations will be required to determine whether any trace of the Doomster Hill survives and how this archaeological resource might be protected in the future.

8.0 Excavation Results

8.1 *Trench A1*

This trench was intended to investigate the site of the Doomster Hill and was positioned over the 1994 and 1996 trial trenches (Figure 22, plates 3 and 4). Initially it was laid out east/west but in due course was extended in all directions to follow specific features. The previous work had shown that this area had been heavily affected by the construction of tenements, the dye works and, most significantly, by the shipyards which had left deep concrete structures. The previous work also revealed that key deposits were located approximately 2 m below the modern ground surface; therefore, this trench had to be large enough to expose the features and the sides had to be stepped to allow the work to proceed safely.

Excavations started by reopening the previous trenches (cut 030 and fill 031), beginning with the removal of deep (up to 0.8 m thick) layers of gravel (069) that formed the surface of the car park, which sealed extensive deposits of demolition material and overburden (001/070) and *in situ* concrete. Once the backfill of the previous trenches had been identified and re-excavated, the trench was then extended to the east and west. The first structural features encountered were associated with the tenements which previously stood on the southern boundary of the study area. These included a ceramic sewer pipe running east/west (071 and 072) into a concrete and brick manhole (011/012). Adjacent to this was a large concrete foundation base for a crane with the stump of a steel girder bolted to it (013). These two structures were too substantial to remove and are visible in many of the excavation photographs. Much of the superficial building rubble derived from the tenements, which had been thoroughly demolished. Only the deepest courses of foundations, running east/west (065) and consisting of massive sandstone blocks (up to 1.5 x 1 x 0.5 m), remained from a tenement. Carefully removing these foundations and associated demolition deposits allowed the levels that had not been disturbed by the tenement construction to be exposed.

The most substantial built features in this trench were a series of curving walls running east/west, which defined the southern boundary of the dye works and then the shipyard. These included a lime-mortared stone wall (114) within a foundation/demolition trench (179); the trench had been backfilled with loose mortar rubble (115 and 117). To the south of the rubble (115) was a spread of orange clay (116), probably from the dye works. The soil matrix surrounding the clay (116) consisted of brown silt with conspicuous inclusions of coal (111), which was observed in various locations in this trench. As the stone wall (114) was exposed, it became clear that it had been partly replaced by a continuous line of concrete walling, which was angled rather than curved. The concrete walls incorporated boundary iron plates and tracks for rolling doors. The concrete wall footings defined the edge of an extensive reinforced concrete surface (014) which ran to the north and east, and which could not be penetrated with the plant available. Moving towards the west there was a change in concrete foundation (278): the stone wall (017) was not present and was replaced by a red brick and concrete foundation (023) built within a foundation trench (075) that was filled with a mixed deposit of brown silt and bricks (076).

The presence of the concrete floor largely confined the excavation to the area south and west of the boundary walls, where the tenement foundations and large pits could be removed by machine to reveal an extensive deposit of brown silt (004); we knew this to be characteristic of the upper fill of the ditch thought to be associated with the Doomster Hill. Removing the tenement deposits also exposed areas of clean white sand (002/087), which had been noted as marking the southern edge of the ditch (003) during the earlier excavations. This remarkably soft, clean sand was an undisturbed, natural subsoil that was recognised at various locations during these excavations.

8.1.1 *Intercutting Pits*

Once the demolition rubble and features associated with the tenements had been removed, a series of large intercutting pits were identified along the south-western perimeter of the excavation. These pits were cut from directly below the layer of demolition material and probably relate to the later developments associated with the tenements. The upper fills of these pits were removed in spits by machine to the level where possible Medieval deposits were encountered or the natural sand was revealed. The pits were recorded in plan and in section but were not excavated in a stratigraphic manner (Figures 22 and 24). In the western corner, the sequence was clearly observed. A layer of orange/grey silty clay (040) sealed a number of the pits, some of which were quite extensive: pit (027/080) was not fully exposed but covered an area 1.30 by 2.80 m and was over 1 m deep. The fills were varied and visually distinctive: the upper fill consisted of grey/brown silty clay with no inclusions (028/81), over a brown silty clay with

some stone inclusions (033), below which were lenses of orange clay (079 and 082), a small pocket of silty sand (083), a lens of coal (088) and a small deposit of dark grey silt (084). The repeated digging of these pits had ensured that any earlier deposits were completely removed; however, there were a few locations, eg between pits (005) and (008), which had escaped damage. These were represented by pinnacles of the clean, white sand (002), which indicated that the level of the natural sand subsoil originally was much higher prior to the digging of the pits. The area of pitting was confined to the south-western portion of the trench, and was apparently limited by the presence of the tenements.

To the east of the pits a different sequence was seen (Figure 23), and in places deeper deposits of the white sand (002) were exposed that included one area where faint lenses of mineralization could be observed, suggesting that the sand was a natural subsoil. The most significant structural remains found in this area were the remains of clay-bonded buildings (324, 193/198), which survived below the foundations of the tenements (see below).

8.1.2 *The Ditch*

To the north of the area occupied by the intercutting pits there was less disturbance (Figure 24). The demolition overburden (001/070) sealed deep deposits of dark brown/grey silt (073) that extended to the concrete boundary wall foundations of the shipyard (014/278). This layer sealed the massive ditch (cut 003 and fill 004) which had been previously encountered, but the scale of these excavations allowed the sequence to be better understood. Once the trench had been cleaned and planned, a slot was excavated by hand through the ditch fill (Figure 25, plates 5 and 6); initially the slot was 1 m wide but it was later widened by another 1 m for safety reasons to allow the side to be stepped.

Removing layer (073) by hand revealed a lighter brown and sandier soil (074) resembling the upper layer of the ditch fill (004). It was also possible to identify a thin layer of silty yellow sand (085) that appeared to mark the edge of the ditch and to recognise a dark brown silty layer (086) as a buried ground surface dating to when the ditch was excavated. It also presented a puzzle, in that the fill of the ditch appeared to rise significantly above the original ground level. We believe that this was because the boundary wall of the dye works/shipyards acted to retain the fill material during the infilling process.

The ditch fill exhibited subtle differences, representing different dumps or tipping episodes, which were interpreted as representing a rapid process of infilling. The upper fill (004/074) was a loose dark brown silt that contained charcoal and a mixture of finds, including Medieval pottery along with glass fragments. Towards the middle of the ditch the deposits (174) were darker brown and contained more clay, while at the northern side of the ditch there was evidence of disturbance to the fill for the modification of the boundary wall (114, 179, 117). Towards the base of the ditch the deposits became increasingly more clay-rich (174, 176, 250, 256), and these layers appear to represent a slower silting process. The deepest deposits were grey silty clays (175, 249, 199), which sealed a compacted sandy gravel (177) containing a large fragment of a light green glass rectangular (case) bottle of eighteenth-century date, probably originally a gin bottle. The base of the ditch was defined by a level layer of orange sandy gravel (178) with large rounded stones up to 0.18 m in size.

Approximately 276 sherds of late Medieval pottery, including some quite large rim and base sherds, were recovered from throughout the fills of the ditch. This suggests that the material came from archaeological deposits of Medieval date, presumably close by to judge from the good condition of the pottery fragments. It is possible that the Doomster Hill itself may have provided the main source for the infill. The eighteenth-century gin bottle indicates that the ditch was filled around the time that the settlement and industry of Govan were expanding.

8.1.3 *Southern Extension*

In an attempt to establish the extent and orientation of the ditch (003) the trench was extended south to the limit of the available area. Removal of the rubble overburden (001) and the tenement foundations (065) revealed a series of deposits and features of early modern or perhaps late Medieval date. These included a stone foundation (066) similar to the wall (065) to the north; although these walls were parallel, they appear to represent different buildings, not least because smaller stones were used in the construction of (066). Between these two wall foundations was an extensive deposit of ash and cinders with lenses of orange clay (068). To the south and adjacent to foundations (066) was a ceramic drain formed of U-shaped tiles (067). The stone foundations, the layer of ash (068) and the drain (067) were set upon the same layer of deep layer of brown silt (144/004/074) that was seen to cap the ditch throughout the trench. Beneath the foundations (065) was the remains of an earlier clay bonded wall (324) (plates 7 and 8)

To further investigate the layer of brown silt (144), a metre-wide slot was excavated on the line of the drain and stone foundations, as it appeared that this location had already been subject to later disturbance. Excavation revealed a small pit against the eastern baulk (145). The upper fill consisted of orange silty clay (146); this sealed another deposit of more mottled orange silty clay (147) which in turn sealed a layer of clean orange clay (148). These deposits are thought to be associated with the dye works. The pit had been dug into a deep layer of brown silt that included coal and cinders (132). All of these deposits post-dated the main brown silt layer (144), which overlay the clean natural sand (002). The surface of the sand sloped gently to the east, possibly suggesting the remains of the lip or cut (131) for the ditch. To determine whether this did in fact mark the lip of the ditch, a second slot was opened to the south of the foundations (066).

This eastern extension was 2 by 2 m wide (Figure 26, plates 9 and 10) and limited to the east by the presence of the boundary wall of stone (114) replaced by concrete (014) and the stone wall (114). The construction trench (179) for the boundary wall cut through two distinct rubble deposits, both containing sandstone and bricks (252 and 251). This rubble sealed a brown silty soil with frequent orange clay inclusions (196), which in turn sealed a paved surface of cobblestone and bricks (373). These features may have been contemporary with the remains of the corner of a clay-bonded building consisting of east/west (193) and north/south (198) walls. The latter wall (198) ran below the mortared-stone boundary wall (114) on the eastern edge of the trench. Although walls (193) and (198) formed a corner, another wall continued to the south (197). This wall abutted wall (198) at a slight angle and was of a completely different build and re-used dressed stones. This wall may be the lower courses of wall (114).

Clay-built walls (193) and (198) were similar in build to the clay-built wall (324) to the north. Wall (193) appeared to run parallel to the main property boundary (114) and may be an earlier manifestation of this boundary. Excavation did not reach the bottom of wall (198), which at this point was approximately 1 m deeper than the level of the sand (002) observed in the adjacent slot to the west. The map analysis (see above) revealed that the course of the burn ran just to the east, and was canalised in the mid-nineteenth century and eventually culverted. The sloping old ground level (086) may well represent the bank of the burn and suggests the wall (198) was built to manage the burn.

These clay-built walls are fragments of the earliest buildings uncovered during the excavations. Given the small portions examined, it is impossible to identify their functions. They could represent dwellings or outbuildings. They are significant because they pre-date the reorganisation of Govan that took place during the nineteenth century. There is every likelihood that they are seventeenth-century in date, but given the presence of large quantities of late Medieval pottery found nearby they could have formed part of the Medieval village. Certainly they would merit detailed excavation prior to any redevelopment work.

8.1.4 *Northern Extension*

The boundary wall of stone (114) and the concrete surface (014) obscured the northern side of the ditch, so an effort was made to investigate beyond the wall to the north. Extending the trench to the north exposed an extensive reinforced concrete floor (014/055) within which were set iron strips, which presumably served as a track for a crane or other heavy equipment. A chance break in the concrete 1 m north of the boundary wall was just large enough to allow the machine bucket to investigate the deposits below the concrete floor.

Initially, a 5 m long slot was opened up (Figure 25, plates 11-13) which revealed a complex sequence of demolition debris, including brick rubble (056 and 058), a fragmentary flagstone surface (057), an extensive layer of compacted sandstone rubble (053) and, next to the concrete boundary wall, a deep deposit of voided rubble (050) consisting of fragments of large sandstone blocks up to 0.5 m in size. This massive rubble sealed a substantial brick culvert (051) capped with stone slabs (063). At the northern limit of this trench a fragment of a stone wall (064) was noted. Where it was possible to safely gain access to this trench, a sequence of clays, coal and ash (052, 047, 045, 090, 091) were observed to overlie layers of clean, gritty orange sand (092) and yellow sand (093).

To ensure that the ditch with its potentially Medieval deposits did extend beyond the boundary walls, the slot was extended by an additional 4 m. Here a similar sequence of deposits were uncovered below the concrete floor, including a layer of sandstone rubble (095) over grey ash (096), coal dust (097) and brick-built walls (100 and 105), a brick surface (101) and a masonry walls (106, 064). Directly over the floor was a deposit of bright orange clay (107). Similar deposits were recorded during the earlier phase of work and are thought to be associated with the dye works. Below the structure, a similar sequence of deposits was revealed. The clays, silts and ash and coal (052, 045) sealed clean gritty orange sand (092).

This layer appeared to be the natural undisturbed subsoil. Therefore, the northern limits of the ditch would appear to lie directly under the boundary wall. Indeed, it would appear that the boundary wall follows the line defined by the ditch.

Extensive remains of the dye works are present under the shipyard floor levels; however, they appear to be entirely subsurface features. Although no above-ground traces of the dye works survive, the surviving remains may provide valuable information about the processes undertaken in the works. However, these will only be understood through large-scale, open area excavation.

The extensively pitted area in the south-west of the trench was originally thought to relate to the dye works, but subsequent map work has indicated that this was never part of the works. The intensity of the pitting raises the possibility that the fine white sand close to the surface here was being extracted for some small-scale industrial use. More refined examination of the pits would be required to determine the processes involved.

8.2 *Trench A5*

This trench (Figure 27, plate 14) was intended to examine the east frontage of Water Row and to link up with Trench A1, to follow the ditch (003) which was thought to be associated with the Doomster Hill.

At the east end of the trench it proved difficult to establish a link with Trench A1 because of the presence of a concrete floor with iron strips on the upper surface (278). The large concrete foundations were the western continuation of foundations uncovered in Trench A1 (014/055); here they were composed of several layers of brick and concrete (295, 296 and 297), which was up to 1 m thick over the culvert (see below). To the south of the concrete foundations was a deep deposit of brown silt (281), comparable to the silt (004/074) filling the ditch in Trench A1. A gap in the concrete floor (278) allowed limited excavation to continue below the floor level, where the brown silt (280) containing brick and other building debris overlay dirty yellow sand (292), loose brown silt with patches of grey clay and further demolition debris (293) and compacted brown silt with patches of yellow sand and inclusions of coal (294). All of these deposits sealed the same brick-built, stone-capped culvert (282/283) originally uncovered in Trench A1 (051/063). Excavation in the narrow space to the north of the culvert showed that a further 1.8 m-thick layer of the silt with sand and coal (294) lay above the natural sand. Although this layer was mixed with orange/brown silty clay (307) and contained several lenses of clay and sand, it did not correspond to the sequence of deposits in the ditch (003) examined in Trench A1.

The depth at which undisturbed natural soils were discovered was approximately 1.5 m shallower in Trench A5 than the base of the ditch (003) in A1, so it would appear that the construction of the culvert and subsequent building work cannot account for the absence of the ditch in this area. It most likely never extended much further west of Trench A1.

At the west end of Trench A7, the excavations were intended to investigate domestic occupation on Water Row, for which there is ample map evidence. Closest to Water Row, the gravel surface (284) of the car park immediately overlay a deep deposit of loose brick rubble (285), which extended to a depth of 2.5 m below the present ground surface before giving way to clean white sand. This rubble probably represents the tenement remains dumped into a cellar, although no evidence for a floor was present. Moving further east, the archaeological remains were shallower and in places the natural sand was close to the surface. The red brick wall (287) running north/south appears to have been the back wall of the tenement shown on the OS second edition. This wall was partly built upon an earlier stone-built wall (288) that appeared to sit on mixed foundation layers consisting of ash and tar (290) and rubble and tar (291). This earlier wall is evidently part of the pre-tenement building shown on the OS first edition and on Martin's 1842 map. Further east, superficial spreads of mixed demolition and construction rubble sealed various services, including a drain pipe (289) and other features associated with the backcourt of the tenement (300, 301, 305, 289). The back yard of the tenement appears to have been marked by the remains of a modest brick wall (302).

Subsequently, the wall of the back court was removed by the insertion of a substantial service trench (260) containing a brick-built, stone-capped culvert (263/262) that curved to the south-east. Judging from the material used in the culvert, this may have served the dye works. Further east again, a series of lightweight concrete strip foundations (273, 274, 275) built upon a spread of dark grey gravel (272). To the east of the north/south foundation (275), mixed layers of sand and silt (294, 307) and a circular pit (322) showed a degree of reworking that could be associated with either the dye works or the shipyard.

8.3 *Trench A7 (northern extension to A5)*

This trench was located between the extensive concrete foundations exposed in Trenches A5 and A1 in an attempt to locate the ditch (003) examined in A1 and was linked to Trench A5 (Figure 27, plate15).

Excavation started at the northernmost concrete foundations and extended north. The upper gravel layers of the car park (284) were removed to reveal a mixed brown silt and rubble layer containing bricks and other demolition debris, including iron girders (316), that extended throughout the trench. This sealed another extensive layer of brown silt with frequent inclusions of coal (310) similar to possible ditch fill (280) and (281). As the trench was extended, an edge or cut (309) was uncovered just below layer (316), which suggested that this was the result of a comparatively recent disturbance. North of the cut, (316) overlay another dark brown silty layer (312), similar to (310) but with more sand and clay banding. Both these layers sealed a silty yellow sand deposit (311) and a layer of clean yellow sand (317), probably natural. In the south-east corner of the trench, closest to the concrete foundations, the layer of silty sand (311) overlay a similar sand layer except that it contained small stones and gravel (318). Further to the north, layer (312) overlay a compacted layer of brown silty clay (313). This in turn sealed a deposit of black sticky clay that contained abundant coal (314) and a sticky orange brown clay deposit (315) similar to deposits thought to be associated with the dye works. These deposits were not investigated. They appeared to be rising to the north.

To further investigate the deep deposit of brown silt (310) with the cut (309), an extension to the trench was excavated to the west. Further cleaning revealed that this was in fact a large pit (320) filled with grey/brown clay and rubble (321) that extended to the west for 1.4 m and had been cut through (310) into the natural sand. To the north was another deposit of brown clay and brick rubble (319) that was not visible in the original extension.

Overall, it is clear that there is not the same depth of archaeology in this area that was observed only 5 m further east in A1. The undisturbed natural sand survives at a much higher level here, which reflects a differential usage of the area, primarily as domestic backlands with only limited industrial activity.

8.4 *Trench A6*

This trench was located to the north of trench A5 in an attempt to examine the survival of archaeological deposits away from the concrete floors which limited excavation in Trenches A1 and A5. This trench was located over a deep deposit of loose concrete and brick rubble that filled a brick-walled, concrete-floored basement. The removal part of the concrete floor to reveal more concrete and brick rubble over another concrete floor. Beneath the second floor natural sand and gravel were exposed at a depth of in excess of 3m below the present ground surface (plate 16). The building in question appears to be associated with the shipyard and first appears on the OS third edition.

8.5 *Trench A2*

This trench was excavated at the northern end of Water Row to examine the nineteenth-century ferry slipway and elements of the dye works (Figure 28, plate 17). As elsewhere, the presence of reinforced concrete constrained the excavation; nevertheless, it was possible to expose the eastern side of the ferry slipway retaining wall.

The wall (128) was built from large regular sandstone blocks and was capped by bricks. The southern face of the wall was the back side and had an irregular finish. Access to the north side was restricted, but here the wall had a well-finished and neatly pointed face. It continued to a depth of 2.4 m, where a spread of yellow mortar (125) over the pale yellow/white natural sand marked the base of the wall. There was no evidence of the cobbled paving seen in various photographs of the slipway in use. The infilling material (127) was a fairly uniform loose sand and gravel, although the upper deposits were more mixed with occasional bricks and lumps of concrete. The foundation trench for the wall was visible on the south side. It appeared to have been cut through a dark brown silt deposit (123) that contained charcoal and several large, deep, intercutting pits that had been cut into the natural pale yellow sand (120).

The rectangular brick structure (348) in the south-east corner of the trench was founded on a concrete pad. Although not depicted on the OS maps, this seems likely to be associated with the later shipbuilding activity. Numerous intercutting pits (130, 355, 369, 367, 368, 357, 359, 360, 365, 372) of various sizes were present throughout the trench. Some of the smaller, flat-bottomed pits may have held timbers for scaffolding, used to support ships during construction in the early shipyard. Such artefacts as were recovered – bricks, tiles and pottery – were consistent with nineteenth-century activity.

8.6 *Trench A8*

This trench was positioned to examine the ferry terminus at the end of Water Row in an area of rough ground between the cobbled surface of the Clyde walkway, the fence around the ferry terminus and the bollards. Unfortunately, here a shallow deposit of topsoil lay directly over a massive concrete surface with iron fittings, which were too substantial to allow further excavation at this location.

8.7 *Trench A3*

This trench was excavated on the eastern side of the study area, in the heart of what had been the dye works and shipyard, to examine any surviving industrial buildings and to locate the culverted burn (Figure 29). It was excavated in two stages to either side of an iron service pipe. The western half of the trench fell within a shipyard shed where paved surfaces constrained the excavations.

In the eastern half of the trench, a variety of materials relating to recent landscaping and demolition were encountered: topsoil and rubble (133), gravel, tarmac and concrete (134, 135), red blaes (136, 138), brick and concrete (137), gravel (139) and clays (140, 141). Here the grey clay (141) was the natural subsoil; it was investigated to a depth of 1 m with no change.

In the western half, the gravel surface of the car park sealed an extensive layer of compacted demolition rubble (165), which overlay floors of concrete (149) and cobbles (164). Between the two was a gap marked by a compacted band of black rubble and building debris (163). This gap enabled the machine to remove some of the cobblestones to investigate the deposits below. This revealed that the cobbles had been laid on an earlier concrete surface (150), as was the concrete floor (149). More importantly, it showed that the gap represented the location of a brick and stone wall (157). This wall was built directly on the orange sand (161), which further investigation established was an undisturbed subsoil covering a horizon of the familiar natural white sand (162).

The features exposed relate to the heart of the dye works. The cobbles probably represent a yard surface adjacent to the culverted burn, with the demolished wall representing the western side of a range of buildings roughly parallel to the burn. The concrete and metal tank would have been features of the interior of the building. All of this was swept away to create an open space for the fabrication of ships, which was not subsequently built upon.

8.8 *Trench A4*

This trench was positioned to examine structures fronting on to the eastern side of Water Row, which might be either domestic or industrial (Figure 30). Removal of the gravel surface and red blaes (167) revealed extensive areas of concrete (184, 189) and cobbling (191). The western end of the trench on Water Row uncovered a brick foundation (180) at the edge of the pavement that may mark the boundary wall of the dye works/ship yard. Next to this was the concrete foundation for a street lamp (181); the iron lamp post had been cut off at ground level. Foundations of sandstone (182) were revealed running approximately north/south. To the east was a compacted rubble layer (183) that contained a metal service pipe along with modern detritus, including plastic. Set within a concrete slab (184) was a metal tank (185) 2.5 by 1 m; this was filled with compacted sandy rubble (186). To the east of the concrete slab (184) was a mixed layer of rubble with frequent inclusions of cobblestones (188) and a small section of intact cobbling (190). These cobbles were set in a concrete surface (189) that extended over the width of the trench. The eastern end of the trench was covered by a large area of intact cobbling (191). A gap between the cobbles (191) and the concrete (189) allowed the deeper levels to be investigated. A trial trench uncovered a large concrete slab (173), the base of which was approximately 1.3 m below the present ground surface; it was set into the natural sand. A large pit (172) to the west of the slab had been cut into the natural yellow sand (171), but was not fully excavated.

The extensive area of cobbling seems likely to represent a paved part of the shipyard or a marshalling area around the ferry slipway. The surface with the tank is likely to represent an industrial building, more probably associated with the dye works than the shipyard.

8.9 *Trench C1*

This trench was located on the west side of Water Row in an area that contained tenements until quite recently and had never formed part of the shipyard (Figure 31). The intention was to investigate both the recent buildings that had occupied the site and any earlier structures, with the particular goal of determining whether Pearce Lane originally was splayed towards its junction with Water Row, making the

corner between the two streets originally wider. It was also intended to test whether the subway had been built using the cut-and-cover method.

Immediately below the superficial surfaces – flower beds (202/224), red blaes (203), tarmac (204) ash and gravel (205) – features and structures relating to the tenements were visible. The most prominent features were the brick walls (214, 238 and 243) and concrete footings (220 and 234) running east/west. Generally speaking, the walls were lightly built and provided with minimal foundations. The most substantial wall (243) had a layer of slate as the upper surviving course, possibly acting as a damp course. This wall formed the common wall between the two blocks. Wall (243) had been built in a foundation trench (246) that was cut into the natural subsoil. The lesser walls marked out the entry closes and internal subdivisions. Lead water pipes (213 and 235) were set in service trenches which followed the closes. These service trenches revealed a more complicated history of use than might have been expected, with multiple fills.

There was limited evidence for buildings pre-dating the tenements. Towards the north end of the trench, a concrete wall (220) running east/west was associated with a substantial spread of demolition debris (208), which may belong to one of several structures depicted on the OS first and second editions. In addition, some of the levelling material between these upstanding features, consisting of demolition material including bricks, ash and stone rubble (217, 227 and 230), may have derived from the earlier structures.

There was no indication of an earlier alignment of buildings that differed significantly from the tenement blocks. Although this trench was located in the backlands of the buildings shown on the early editions of the OS maps, if Pearce Lane had splayed to the north it would have been apparent. Similarly, there was no sign of a construction trench for the subway.

8.10 *Trench C2*

This trench was located on the west side of Water Row to investigate the oldest known dwellings in Govan (Figure 32). It was the most northerly location on the west side of Water Row that was available and was linked to a trial trench excavated in 1996 (Driscoll and Will 1996).

No traces of any domestic dwellings were identified in this trench. Adjacent to Water Row, a cobbled road surface (337) with a kerb oriented east/west survived under flower beds. Elsewhere the trench exposed a concrete floor (338), presumed to be from the Harland and Wolff shed, which was interrupted by more recent disturbances including what was presumed to be a modern service trench and was not excavated. A block of concrete (342) that was 1.2 m wide and 0.6 m deep and ran through the trench at a slight angle may have marked the position of an internal wall in the Harland and Wolff shed. Further west, a disturbance in the concrete marked the position of the 1996 trench. Re-excavation here revealed another concrete foundation (344) at a lower level. This earlier trench was extended to the west to allow the investigation of undisturbed deposits below the concrete. This revealed that the concrete surface (338) was set on a thin layer of mixed silty clay, similar to (341) and up to 0.15 m thick. Below this was a thin lens of silty clay (346), but this was only exposed at the edge of the trial trench. At the west of the trench the concrete surface had a smoother surface incised with parallel channels (346), which presumably held rail tracks for moving equipment and materials around the shipyard. In general, such archaeological deposits as were present sat directly on the clay subsoil.

In this trench it seems clear that the building of the Harland and Wolff shed swept away all the previous structures relating to dwellings on the west side of Water Row.

8.11 *Trench C3*

This trench was positioned on the north side of Pearce Lane to investigate the survival of dwellings pre-dating the development of the Harland and Wolff yard (Figure 33). It was also intended to test whether the subway had been built using the cut-and-cover method.

In this trench, the red blaes surface of the car park (326) overlay an extensive concrete surface (327), which was presumably the floor of the shipyard shed. It was possible to remove the concrete at the southern end of the trench to reveal a thick layer of mixed light brown sand and gravel (329), up to 1 m deep, that overlay undisturbed natural yellow sand (330). To the north of this, a metal service pipe within a shallow cut (328) ran east/west through the trench; the pipe was left undisturbed. The trench was extended for a further 18 m to the north of the metal pipe, where the removal of the concrete revealed a series of large, intercutting pits. The earliest (335) was flat-bottomed, appeared to have a straight side to

the north and was filled with bricks, ash and silty clay (336). This had been cut by a later pit (333), which again was flat-bottomed but had sloping sides and was filled with thin layers and lenses of sand, gravel and clay (334). This in turn was cut by another pit (331) that had a slightly rounded base and sides and was filled with grey/brown clay (332). All three pits were approximately 0.5 m deep. They are provisionally interpreted as evidence of the preparation of the site for the Harland and Wolff shed. Again, no traces of earlier structures or deposits were encountered.

9.0 Summary of Fieldwork Results and Evaluation of Significance

This discussion follows the organisation around the four zones (A-D) used in the discussion of the OS maps (see above, section 7.2). The significance of the findings is considered and the results underpin the recommendations offered in the next section.

9.1 *Zone A: Eastern side of Water Row*

This zone formed the main focus of the investigations that were intended to locate the Doomster Hill, to examine the industrial remains of the dye works and shipyard, and to explore the waterfront around the ferry landing. Clarifying the nature of settlement along Water Row was also an objective of these excavations.

Trenches A1, A5, A6 and A7 were positioned to examine the large ditch thought to be associated with the Doomster Hill. The excavations showed that while this ditch did contain considerable material of archaeological interest, it did not conform to expectations. That is, it did not define the site of the circular mound of the Doomster Hill; instead, it was contained within a plot of land that was in existence from the earliest detailed maps. The ditch and its contents are significant for understanding the development of late Medieval and early modern Govan, but are not in any way related to the Doomster Hill. The ditch may perhaps be related to the extensive evidence for the digging of pits in this trench, particularly in the south-west portion of A1. It may be that the fine natural sand was being quarried for some small-scale industrial purpose and that the ditch was a larger-scale manifestation of this activity.

In addition to the pits and ditches, these excavations located fragments of clay-bonded stone buildings of uncertain date, which at the very latest date to the eighteenth century, and may well be of late Medieval date. These fragments are highly significant, and there is every reason to suppose that more extensive remains await discovery towards the southern end of the study area.

Evidence for the dye works and shipyard was discovered in Trenches A1, A3 and A4. At the southern perimeter of the site, the dye works survived as subsurface remains, including conduits and wall foundations. These were generally capped by reinforced concrete structures and floors associated with the Harland and Wolff yard, and can only be effectively investigated by stripping out the concrete. Elsewhere in this zone, remains which are likely to be associated with the dye works were encountered in A4 and A3, but they survived in poor condition. Again only large scale excavation could recover meaningful evidence for the activities and processes undertaken in these buildings.

The principal evidence for the shipyard was the levelling of the dye works buildings. The site was mostly cleared of these buildings. This was quite clear in Trenches A1 and A3, although some of the buildings in A4 may have been re-used. Evidence for shipbuilding activity was seen in the deep levels towards the river (Trench A2), where large, flat-bottomed pits cut into the natural sand are likely to represent the positions of scaffolding piles used to support the ships as they were being built. The most substantial remains of shipbuilding were the reinforced concrete structures and floors towards the southern boundary of the zone. Archaeologically these structures are of limited interest, since it is not clear that extensive work would do more than reveal the footprints of buildings. Very little artefactual evidence for shipbuilding was seen across the site.

It proved problematic to excavate near the waterfront, so there is nothing to add to the understanding of the riverside's modification that can be gathered from map work and visible remains. However, the east retaining wall for the ferry slipway was located. It survives in excellent condition, so it is likely that the remainder of the former slipway is also present below ground. The archaeological value of this structure is limited, but slipway masonry is attractive and may have some heritage value as part of a redevelopment scheme.

Evidence for domestic activity in the form of tenement remains was present along the southern perimeter of the zone, both along Water Row and facing onto Govan Cross. These were not investigated in detail, but substantial deposits are present. The archaeological value of the residences is that they preserve artefacts which provide important insights into working class life. They represent an important opportunity to examine the social evolution of Govan and should receive due archaeological attention.

Finally, one of the goals of the excavations in this zone was to locate evidence for an earlier road network, especially one linking Govan Old Church to the Doomster Hill. The degree of disturbance observed across the site appears to have swept away all traces of the continuation of a road on the line of Pearce Lane.

9.2 *Zone B: North-western Side of Water Row and Waterfront*

Here no excavation was possible. Although the evidence from Trenches C2 and C3 suggests that the Harland and Wolff plating shed effectively levelled the site, the small-scale excavations in the 1994 and 1996 demonstrated that archaeological deposits of high significance could survive in pockets. Moreover, the depth of deposits observed in trench A2 indicates how much made ground exists towards the riverside, so it should not be presumed in the absence of investigation that there are no deposits of archaeological interest in this zone. The zone still requires archaeological evaluation.

9.3 *Zone C: The Area Around the North Side of Manse Lane and West Side of Water Row*

Three trenches were examined in this zone. Two of them (C2 and C3) fell within the area occupied by the Harland and Wolff plating shed. Here, nothing earlier than the shipyard survived and the shipyard structures were limited to concrete and cobbled surfaces and structures. There is no doubt that more substantial remains would survive on the frontage of Water Row, which was not examined, and the massive foundations for the roof supports probably remain *in situ*. It is questionable how much additional information would be acquired through detailed excavation of these structures. However, it would certainly be of benefit for future regeneration purposes to have a better idea of the nature of the subsurface foundations, and this could readily be achieved archaeologically.

The corner of Manse Lane and Water Row was never part of Harland and Wolff and here traces of dwellings were present. These were poorly preserved and yielded modest finds and heavily damaged structural remains. There was limited evidence for the dwellings which pre-dated the tenements; one might expect better preservation and more artefacts in the backlands of these sites, which were not examined. As with the other side of Water Row, these archaeological remains are of significance for Govan's social history and are worthy of archaeological attention.

9.4 *Zone D: The Area Immediately to the North and East of the Churchyard*

Here no excavation was possible and, as with Zone C, the Harland and Wolff plating shed has had an adverse effect on the archaeological deposits, but it is certain that archaeological deposits of high significance do survive, particularly near the churchyard. The 1994 excavations encountered natural sands at a high level on the north side of the churchyard and little in the way of archaeological deposits; however, it must be anticipated that a greater depth of made ground exists towards the riverside. Therefore, it should not be presumed that there are no deposits of archaeological interest in this zone. This zone still requires archaeological evaluation.

10.0 Recommendations

The following observations are offered as advice for furthering the understanding and improving the conservation of Govan's heritage. They will necessarily be subject to modification by the statutory authorities – Glasgow City Council, West of Scotland Archaeology Service and Historic Scotland.

10.1 *Post-Excavation Requirements*

The evaluation recovered a number of artefacts, including pottery, glass, building materials and clay tobacco pipes, which require to be catalogued and described before they can be presented to the Treasure Trove panel and allocated to a museum. There is also an obligation to see that the results of this fieldwork are published. Both of these related tasks will require additional funding. It is conventional to

produce a costed post-excavation design for the approval of the West of Scotland Archaeology Service. The funding would be expected to come from the project sponsor.

10.2 *Further Evaluation Work*

It would be highly desirable to confirm the precise location of the Doomster Hill and the condition of any archaeological remains, as this is one of Govan's most significant historic sites.

The archaeological potential of the north-east portion of the study area (Zones B and D) remains largely unexplored. Prior to formulating detailed development plans, it would be desirable to conduct intrusive investigations. Based on recent experience, these would have to be conducted after the sitting tenants have moved.

10.3 *Further Mitigation Work*

Future development work is likely to have an adverse impact on the archaeological resources across the site. The following general recommendations will have to be refined in light of specific building proposals. However, at present GUARD recommends the following:

- Full-scale excavation of the structures to the south of the site (ie around Trench A1, adjacent to Govan Cross), including the large ditch which contains Medieval artefacts, the clay-bonded buildings and the area of intercutting pits. These archaeological remains have the potential to reveal aspects of Govan's pre-modern settlement and industrial activity.
- Selective excavation of the sites of tenement buildings, cottage-style dwellings and commercial buildings on both sides of Water Row. These sites have the potential to greatly enhance understanding of Govan's social history during the making of the industrial burgh. Survival of deposits is variable and, as these sites are not particularly complex, they could be excavated economically.
- Controlled monitoring and recording of the remains of Reid's Dye Works as the site is stripped and prepared for construction. This would allow the development of the dye works to be better understood, particularly its water management and the range of processes undertaken here.
- Exposure of the former ferry slipway with a possibility of retention. The substantial masonry remains could be easily exposed and re-used as a feature of a new ferry terminus.

11.0 Acknowledgements

GUARD would like to thank the following people for their assistance during the course of this project. The project was managed for GUARD by Angela Boyle. In the development and run-up to this project we benefited from the encouragement of Glasgow City Council. Councillors Catherine McMaster and Stephen Dornan and from the advice provided by Tom Darroch, Lorraine Edwards, Fiona Burns, Elaine Murray and Alistair MacDonald of the Development and Regeneration Service.

Tommy Docherty from Glasgow South West regeneration Agency. Jim Cunningham and his team from Glasgow Council markets department. David Hodgson and Dr Carol Swanson of West of Scotland Archaeology Service, who monitored this project on behalf of Glasgow City Council. Special thanks to John Moore of Glasgow University Library and Dr Jeffrey Stone Department of geography University of Aberdeen for their advice and help with the map research. Dr David Sanderson, Paul Bishop and Dr Jo Mackenzie for advice on OSL dating and soil deposition. Norie Mackie and staff from the Pearce Institute

The report was copy-edited by Olivia Lelong, desk-top-published by Jen Cochrane and bound by John Carroll. Illustrations were produced by Gillian McSwan, and technical support was received from Aileen Maule and John Kiely.

12.0 Bibliography

Anon 1915-16 'An Old Govan Advertisement', *Transactions of the Old Govan Club* 1(2), 7.

Brotchie T C F 1905 *The history of Govan*. Glasgow: The Old Govan Club [reprinted 1938].

Dalglish C & Driscoll S T forthcoming *Historic Govan*. Historic Scotland, Scottish Burgh Survey. With contributions by I. Maver, N.F. Shead, & I. Shearer.

Driscoll S T & Will R S 1996 *Water Row, Govan*. University of Glasgow (GUARD): unpublished interim report.

Driscoll, S T & R S Will 1997 *Govan Old Parish Church and Water Row*. University of Glasgow (GUARD): unpublished interim report.

Deas, J 1876 *The River Clyde*. Glasgow: James Maclehose.

Hume, J R 1974 *The industrial archaeology of Glasgow*. Glasgow: Blackie.

Leishman, M 1845 'Parish of Govan', in *The new Statistical Account of Scotland*, volume 7. Edinburgh: Blackwood & Sons, 668-718.

MacGeorge, A 1880 *Old Glasgow: the place and the people; from the Roman occupation to the eighteenth century*. Glasgow.

Moore, J N 1996 *The Maps of Glasgow: a history and cartobibliography to 1865*. Glasgow: Glasgow University Library.

Primary Sources

Map of the River Clyde by Thomas Kyle (1838): *Glasgow City Archives, Mitchell Library, Glasgow; archive ref. FCN 14/10*.

Plan and section of proposed dyke at Govan ferry (1852): *Glasgow City Archives, Mitchell Library, Glasgow; archive ref. TCN 14/234*.

Plan and section of south bank at Govan (1859): *Glasgow City Archives, Mitchell Library, Glasgow; archive ref. TCN 14/249*.

Plan of land at Govan by Thomas Kyle (1859): *Glasgow City Archives, Mitchell Library, Glasgow; archive ref. TCN 14/248*.

Plan of properties, Govan (no date): *Glasgow City Archives, Mitchell Library, Glasgow; archive ref. TCN 14/39/2*.

Plans and Sections of proposed work at Harland and Wolff Govan Yard (1913): *Glasgow City Archives, Mitchell Library, Glasgow; archive ref. TCN 19/267*.



*Plate 3:
Trench A1 general view from NW.*



*Plate 4:
Trench A1 general view from W with line of the 'ditch' shown by the white sand.*



*Plate 5:
Trench A1 detail of W section with possible old ground surface.*



*Plate 6:
Trench A1 section through the 'ditch' from the S.*



*Plate 7:
Trench A south – location of earlier wall from the SW.*



*Plate 8:
Trench A1 south – detail of earlier wall N from the SW.*



*Plate 9:
Trench A1 south – detail of earlier walls S from W.*



*Plate 10:
Trench A1 south – detail of earlier walls S from S.*



*Plate 11;
Trench A1 northern extension with culvert from W.*



*Plate 12:
Trench A1 northern extension detail of natural sands.*



*Plate 13:
Trench A1 northern extension with brick structures.*



*Plate 14:
Trench A5 from the NW.*



*Plate 15:
Trench A7 showing natural sand from E.*



*Plate 16:
Trench A6 deep deposits of brick and concrete from E.*



*Plate 17:
Trench A2 general view from the W.*

13.0 Appendices

13.1 *Map Sources*

<i>Mapmaker</i>	<i>Year</i>	<i>Map Name and Scale</i>
Timothy Pont	1583-96	Renfrewshire
Robert Gordon	1636-52	Barony of Renfrew.
Joan Blaeu	1654	The Baronie of Renfrow
John Adair	1685	A mape of the west of Scotland containing Clydsdail, Nithsdail, Ranfrew, Shyre of Ayre, & Galloway
Herman Moll	1745	The Shire of Renfrew with Cuningham [ie Cunningham]. The North Part of Air [ie Ayr]
William Roy	1747-1755	Military Survey of Scotland (sheets 05/5d and 15/5d)
Charles Ross	1773	A map of the shire of Lanark
George Taylor & Andrew Skinner	1775	Plate 12 The road from Edinr, to Glasgow & Greenock & to Dunbarton & Inveraray. Continued. Survey and maps of the roads of North Britain or Scotland 1776
Thomas Richardson	1795	Map of the town of Glasgow & country seven miles around
John Ainslie	1800	Map of the County of Renfrew
William Forrest	1816	The county of Lanark from actual survey
John Thomson & William Johnson	1820	Renfrew Shire
John Thomson & William Johnson	1820	Northern Part of Lanarkshire. Southern Part
John Ainslie	1821	Map of the Southern Part of Scotland
David Smith, James Cleland & John Wood	1822	Map of the ten parishes within the Royalty and the parishes of Gorbals Barony of Glasgow
James Cleland & David Smith	1832	Map of the ten parishes within the Royalty... of Glasgow
George Martin	1842	Map of the City of Glasgow
Thomas Kyle	1842	Map shewing estate of Milton

13.2 *List of Contexts*

<i>Area</i>	<i>Context</i>	<i>Description</i>	<i>Interpretation/Relationships</i>
Trench A1	001	Grey silty clay with inclusions of brick and stone rubble	Rubble infill – from dye works
Trench A1	002	Sand - same as 087	Natural sand
Trench A1	003	Linear feature/edge	Cut of ditch – Doomster hill – filled by (004, 174, 178)
Trench A1	004	Brown sand with occasional inclusions of charcoal flecks	Upper fill of doomster ditch
Trench A1	005	Oval pit (same as 062)	Cut of dye works pit – filled by 007, 006, 035
Trench A1	006	Orange clay	Fill of dye works pit [005/062]
Trench A1	007	Orange/brown silty clay	Fill of dye works pit [005/062]
Trench A1	008	Truncated feature, cut by dye works pit [005/062]	Cut relating to dye works – filled by (038, 009, 034)
Trench A1	009	Orange/brown silty clay	Fill of dye works pit [008]
Trench A1	010	L shape concrete block with brick	Foundations of tenements
Trench A1	011	Brick and concrete walling	Manhole associated with shipyard or tenements
Trench A1	012	Dark brown silt	Fill of manhole
Trench A1	013	Concrete and steel	Foundation for shipyard crane/machinery
Trench A1	014	Concrete floor with occasional groves and small holes, built on a brick and concrete foundations	Concrete floor of shipyard building
Trench A1	015	Red brick, bounded with mortar	Foundation wall of shipyard 014
Trench A1	016	Concrete block	Concrete base foundation of shipyard
Trench A1	017	Orange clay	Deposit from dye works – located against (114)
Trench A1	018	Linear feature	Cut for service trench – shipyard/tenements
Trench A1	019	Gravelly silt matrix with inclusions of brick rubble	Fill of service trench [018] – contains clay drainage pipe at base
Trench A1	020	Dark brown silt with inclusions of coal	Lower fill of service trench [018]
Trench A1	021	Oval in plane cut	Cut of foundation trench for tenement/large pit – filled by (022)
Trench A1	022	Dark brown silt	Fill of foundation [021]
Trench A1	023	Red brick , capped by concrete bounded with rough mortar	Brick and concrete structure associated with shipyard
Trench A1	024	Red brick wall same - as (056)	Brick wall at northwest end of trench
Trench A1	025	Linear feature	Cut of brick lined drain between (023, 024)
Trench A1	026	-	Brick lining of [025]
Trench A1	027	Cut	Cut of dye works pit – filled by (033, 028)
Trench A1	028	Grey brown silty clay	Fill of dye works pit [027]
Trench A1	029	Cut	Cut of dye works pit – filled by (02=32, 039)
Trench A1	030	Cut of rectangular feature	Cut of pervious 1990's evaluation trench
Trench A1	031	Dark brown/grey silt sand and rubble	Backfill of 1990's evaluation trench [030]
Trench A1	032	Grey/brown silty clay	Lower fill of dye works pit [029]
Trench A1	033	Very silty clay with inclusions of pebbles	Lower fill of dye works pit [027]

<i>Area</i>	<i>Context</i>	<i>Description</i>	<i>Interpretation/Relationships</i>
Trench A1	034	Grey/brown silty sand with occasional pebbles inclusions	Fill of dye works pit [008]
Trench A1	035	Grey/brown clay silt	Upper fill of dye works pit [062, 005]
Trench A1	036	Cut and fill of modern service trench	ceramic sewer pipe
Trench A1	037	Grey/brown silty clay	Fill of dye works pit [029]
Trench A1	038	Orange/brown silty clay	Lower fill of [dye works pit [008]
Trench A1	039	Orange/brown silty clay	Upper fill of dye works pit [029]
Trench A1	040	Orange/grey silty clay	Deposit post dating dye works pits [027, 029]
Trench A1	041	Linear feature orientated east/west and truncated by (056), truncates/cuts into (048, 044, 046, 053)	Cut of pit/drain – filled by (042, 043)
Trench A1	042	Dark grey sand	Upper fill of pit/drain [041]
Trench A1	043	Mottled yellow/orange gravelly sandy and clay	Primary fill of pit/drain [041]
Trench A1	044	Brown clay	Several dump episodes of clay/gravel possibly associated with dye works – fill of pit [060]
Trench A1	045	Clay deposit	Unknown function, although appears to be earlier than the presumed dye works wall
Trench A1	046	Bright orange silty clay	Deposit/dump associated with dye works – industrial waste
Trench A1	047	Black sandy fine gravel (ash)	Thin deposit – debris from fire – dumped not burnt in situ
Trench A1	048	Black hardcore material – ash like composition	Dump/deposit of fire – industrial propitious/use
Trench A1	049	Sandstone rubble	Rubble material from demolition of wall (050)
Trench A1	050	Sandstone blocks bonded with mortar (059) – truncated by ship yard (053, 057, 054, 055 and drain 051)	Foundation of wall or dye works – (049) is the demolition remains of this wall
Trench A1	051	Brick lined culvert – sandstone capped – cement bounded – linear running northeast/southwest	Brick lined drain/culvert possibly associated with the shipyard
Trench A1	052	Dark grey clay with inclusions of coal flecks	Clay deposit – possible natural indications of bioturbation
Trench A1	053	Yellow degraded pieces of sandstone with clay inclusion	Layers of degraded sandstone – possible associated with tenements
Trench A1	054	Dark grey clay	Deposit associated with domestic use – located above dye works but below shipyard, may be associated with tenements
Trench A1	055	Linear Concrete block	Earliest level of shipbuilding
Trench A1	056	Structural deposit of brick sitting within (048) – same as 024	Brick surface associated with brain
Trench A1	057	Structural deposit – similar to the degraded sandstone (052) with large sandstone slabs in situ	Possible surface associated with the tenements/domestic – as is located above the dye works (050) and bellow the ship yard (055)
Trench A1	058	Structural deposit – brick and cement dump – used to level ground surface for the construction of shipyard	Made ground – levelling

<i>Area</i>	<i>Context</i>	<i>Description</i>	<i>Interpretation/Relationships</i>
Trench A1	059	Structural deposit – bonding of wall (050) – brown mixed silty clay with deposit (046)	Bonding of wall (050)
Trench A1	060	Cut of pit	Possible cut of pit associated with dye works – filled by (044)
Trench A1	061	Yellow/grey sand – similar to (053)	Deposit associated with drain/surface (056)
Trench A1	062	Same as [005]	-
Trench A1	063	Structural deposit – sandstone blocks – dry stone – linear in plan running northeast/southwest	Cap stones of a brick lined culvert or drain (051)
Trench A1	064	Structural deposit – sandstone blocks, bonded with lime mortar like martial large stone foundations	Wall of dye works
Trench A1	065	stone foundations	Foundations for tenements S
Trench A1	066	ceramic land drain	Tenement foundation s to S
Trench A1	067	ash and cinder deposits	Horse shoe shaped drain
Trench A1	068	Green grey gravel	Associated with tenements
Trench A1	069	Brick tile and stone rubble layer with dark grey silt	Hardcore layers of car park
Trench A1	070	Cut of steep sided – slightly concaved sides – with flat base pit	Demolition/levelling layer overlaying shipyard remains
Trench A1	071	Mixed grey/orange/brown silt with frequent coal and cinder inclusions	Cut for shipyard services trench – filled by (072, 089)
Trench A1	072	Dark brown silt – light sand	Fill of service trench [071]
Trench A1	073	Brown silt/and with inclusions of modern material	Possible fill of ditch/mound material of Doomster hill
Trench A1	074	Cut with straight sides to flat base	Possible upper fill of ditch/mound, merging with (073) above – interface with [085] – possible cut for ditch
Trench A1	075	Mixed brown silt/sand with lenses of orange sand	Cut for shipyard wall (023) – filled by (076, 023)
Trench A1	076	Dark brown silt/sand inclusions of brick, stone and concrete rubble	Fill of foundation cut [075] shipyard
Trench A1	077	Irregular side to a flat base pit	Fill of shallow pit [078]
Trench A1	078	Orange/grey clay with inclusions and lenses of orange darker clay – truncated by 070, 071	Cut of shallow pit – filled by (077)
Trench A1	079	Steep sided pit – truncated by 078	Upper fill of dye works pit [080]
Trench A1	080	Dark brown silt with slight sand content with inclusions and lenses of grey silt	Cut of dye works pit – not bottomed filled by (081, 082, 083, 088, 079)
Trench A1	081	Dark grey silt with orange/grey clay patches	Main fill of dye works pit [080]
Trench A1	082	Mixed brown/yellow sand and brown silt with darker grey silt patches	Small deposit in dye works pit [080]
Trench A1	083	Very dark brown silt with occasional coal/coke inclusions	Small deposit in dye works pit [080]
Trench A1	084	Mixed yellow sand with patches of brown sand/silt	Fill of dye works pit [080]
Trench A1	085		Possible disturbed layer at base of Doomster Hill ditch/natural sand

<i>Area</i>	<i>Context</i>	<i>Description</i>	<i>Interpretation/Relationships</i>
Trench A1	086	Dark brown silt sand with occasional coal inclusions	Possible old ground surface
Trench A1	087	Light yellow sand	Natural sand
Trench A1	088	Dark grey silt with occasional coke/coal inclusions	Thin deposit in dye works pit [080]
Trench A1	089	Fired clay	Clay pipe – drain – associated with shipyards
Trench A1	090	Grey silty clay	Alluvial deposit – earlier than dye works, either associated with flooding event or part of river Clyde
Trench A1	091	Dark grey silty clay – similar to alluvial clay deposit (045, 090) truncated by wall foundation (050)	Natural alluvial deposit – either as the result of flooding or as part of the river – cut of dye works
Trench A1	092	Orange gritty sand – truncated by wall associated with (045, 090, 091)	Natural alluvial deposit – part of natural alluvial banding
Trench A1	093	Yellow brown sand	Natural sand
-	094	Number not used	-
Trench A1	095	Dirty yellow degraded sandstone material	Degraded sandstone – used as hard packing, ground leveller – possibly associated with later tenement occupation
Trench A1	096	Dark grey ashy grave part sand – abuts (100) similar to (098)	Ashy gravel deposit dumped material from tenement occupation or dye works activity
Trench A1	097	Black coal/charcoal – part of general dumping episodes similar to (096, 098)	Fire dump – either domestic form tenement or form dye works
Trench A1	098	Mixed dark grey coarse mainly silt ash and gravel material - similar to (096, 098) abuts (100)	Dumping deposit, mixed with dye works material
Trench A1	099	Black ash like material coal/charcoal deposit – bellow (101)	Ash like deposit – possibly associated with a furnace (102) and possible brick surface (101)
Trench A1	100	Bonded brick wall with cement mortar	Brick wall associated with dye works
Trench A1	101	Brick surface – bonded with cement mortar	Brick surface – possible indication of industrial activity
Trench A1	102	Hard compacted black coal/charcoal deposit	Industrial activity deposit
Trench A1	103	Brown silty clay with inclusions of charcoal/coal flecks	Silty clay deposit – may be associated with wall (100)
Trench A1	104	Dark grey silty ash/coal gravel	Build up of silts within the culvert (105)
Trench A1	105	Brick, mortar bonded wall	Brick lining form drain/culvert
Trench A1	106	Sandston wall – possible indication of mortar surrounding the stones – east/west alignment	Wall associated with the dye works
Trench A1	107	Bright orange silt	Dye works deposit
Trench A1	108	Orangey brown gravelly silt	Natural alluvial deposit
Trench A1	109	Dark grey sandy silt with occasional flecks of charcoal/coal	Natural alluvial deposit
Trench A1	110	Same as 004 (not excavated)	
Trench A1	111	Grey brown silty clay	Upper fill of ditch
Trench A1	112	Orange clay silt	Fill of dye works pit (005) at base of trench

<i>Area</i>	<i>Context</i>	<i>Description</i>	<i>Interpretation/Relationships</i>
Trench A1	113	Dark grey/brown silt with stone rubble inclusions - unexcavated	Next to tenement foundation (010) – may be associated – but unexcavated so unknown
Trench A1	114	Sandstone blocks, bonded with mortar – linear in plan	Sand stone wall – probably associated with dye works – or early boundary wall
Trench A1	115	Golden brown silty sand with inclusions of rubble	Rubble fill of foundation cut to wall [114]
Trench A1	116	Orange silt	Dye works deposit
Trench A1	117	Brown/grey mixed silty/sand	Fill of foundation cut [179]
Trench A2	118	Black sand/gravel	Fill of foundation trench, rubble and gravel sand – associated with slipway of shipyards
Trench A2	119	Dirty brown yellow sand	Natural alluvial sand deposit
Trench A2	120	Orange sandy gravel	Natural sandy gravel deposit – cut by pit [130] and trench [124]
Trench A2	121	White sand	Natural sand deposit
Trench A2	122	Black silty clay with occasional brick and stones and charcoal	Initial deposit of pit [130] – may be associated with dye works - similar pit pits found in trench A1
Trench A2	123	Brown silty sand with inclusions of charcoal flecks	Unknown – possibly old surface
Trench A2	124	Dark grey sandy silt with inclusions of charcoal	Possible fill of pit – may be associated with (122)
Trench A2	125	Yellow – mortar like deposit with inclusions of stone from wall [128]	Mortar and stone deposit – possibly associated with wall [128]
Trench A2	126	Linear brick wall – cement mortared – running northwest/southeast	Brick wall – appears truncated shipyard wall [128] – possibly later modification to [128]
Trench A2	127	Dark grey/brown silt	Back fill deposit – fill between gap in walls [128]
Trench A2	128	Sandstone blocks, faced on northern side, bonded by cement – linear in plan running east/west	Sandstone wall brick capped – part of shipyard – dry dock/slipway
Trench A2	129	Linear cut filled by (118)	Cut of foundation trench for shipyard wall
Trench A2	130	Cut of pit	Cut of pit beneath shipyard concrete surface
Trench A1	131	Cut of ditch – same as (003)	Cut of ditch as seen in slots 1 and 2 southern extension – filled by {132, 144} – cut by later structures [192](193)
Trench A1	132	Light/mid brown silt with inclusions of tree roots, moderate amount of cinders	Upper fill of ditch [131] – possibly a deliberate infill – likely to be medieval
Trench A3	133	Brown with stone and brick rubbles just beneath the surface	Topsoil and rubble – present at the east end of the trench
Trench A3	134	Brick/tarmac	Tarmac surface of car park – with broken tarmac beneath
Trench A3	135	Grey/brown	Broken tarmac layer – levelling surface
Trench A3	136	Red/brown gravel	Red blaze – levelling surface
Trench A3	137	Dark grey/brown silt/and with inclusions of brick and stone	Demolition/levelling deposit – only observed at the east end of the trench

<i>Area</i>	<i>Context</i>	<i>Description</i>	<i>Interpretation/Relationships</i>
Trench A3	138	Same as (136)	Thin red blaze levelling layer
Trench A3	139	Black/grey gravels and pebbles	Waste/levelling layer
Trench A3	140	Dark grey/brown very mixed clay	Re-deposited natural clay – mixed with (139)
Trench A3	141	Grey clay	Natural clay at base of trench
Trench A3	142	Cut of service trench	Service trench for shipyard – filled by (143)
Trench A3	143	Very mixed grey brown silt	Fill of service trench [142] for shipyard
Trench A1	144	Light brown silt with inclusions of moderate cinders	Lower fill of ditch [131] – could be a build up of alluvial deposit – or deliberate infill
Trench A1	145	Cut of possible circular pit	Cut of pit related to dye works – truncates ditch fill (132) – filled by (176, 147, 148)
Trench A1	146	Orange silty sand w/ clay – very wet	Upper fill of pit [145] – related to dye works
Trench A1	147	Mottled grey brown and orange silty clay	Middle fill of pit [145] – likely to be intended to seal off (148) prior to depositing (146) – related to dye works
Trench A1	148	Orange dye	Lower fill of pit [145] – a deposit of dye related to the dye works
Trench A3	149	Concrete slab	Floor of ship building – last phase
Trench A3	150	Concrete slab – 18 cm thick – inclusions of red brick and sandstone	Floor of factory – shipbuilding – early phase
Trench A3	151	Black/brown ash sand layer	Levelling layer of concrete slab (150) – truncated by [160]
Trench A3	152	Black/brown mixed deposit of clay and sand with inclusions of ash/charcoal	Re-deposited industrial material
Trench A3	153	Light brown/yellow sand with inclusions of brick, tiles and rubble	Demolition layer for early building – used th level site before shipyard
Trench A3	154	Black/grey layer of ash and charcoal	Possible old ground horizon
Trench A3	155	Yellow/white sand	Wind blown sand – indicating period of disuse
Trench A3	156	Black/brown ash and sand deposit with inclusions of brick and stone	Demolition layer of wall (157)
Trench A3	157	Structure of brick and stone wall – bonded with mortar and constructed of stone facing and brick infill	Foundation of early wall – earliest phase
Trench A3	158	Linear in appearance running northwest/southeast with the return running north/south – wall at least 4 courses deep	Cut of wall filled by (157)
Trench A3	159	Brown silty with inclusions of building rubble and brick, wood, plastic and cobbles	Demolition rubble – placed or bumped in cut after removal of wall [160]
Trench A3	160	Linear cut running northwest/south east across trench	Cut of robbed out wall
Trench A3	161	Yellow/orange mixed sand	Natural sand
Trench A3	162	Light grey very fine sterile sand	Natural
Trench A3	163	Black/brown ash silt with inclusions of charcoal/stone and rubble	Cap of rubble on robbed out foundation trench [160]
Trench A3	164	Cobbled stone surface – bedded into red fine gravel	Road or court yard for ship building

<i>Area</i>	<i>Context</i>	<i>Description</i>	<i>Interpretation/Relationships</i>
Trench A3	165	Brown silt/sand with inclusions of rubble/brick stone plastic metal	Demolition rubble – used to level car park
Trench A3	166	Red gravel	Red blaze – car park levelling gravel
Trench A4	167	Red fine silty gravel	Red blaze to level car park
Trench A4	168	Light brown/yellow silty sand	Upper fill in large pit [172]
Trench A4	169	Brown silty sand with inclusions of red gravel (red blaze)	Fill of large pit [172]
Trench A4	170	Brown silty sand	Lower fill of large pit [172]
Trench A4	171	Yellow sand	Natural sand
Trench A4	172	Cut of large pit – with sloping sides to flattish base	Cut of large pit – filled by (168, 169, 170)
Trench A4	173	Concrete slab – 1 metre thick	Concrete block – foundations
Trench A1	174	Dark brown silty clay sand with occasional charcoal inclusions	Latest fill of Doomster ditch – like (004)
Trench A1	175	Grey silty clay	One of a series of clay and gravelly clays deposited within the mid section of the ditch -
Trench A1	176	Grey with orange flecks clay	Clay lens with organic inclusions – either represents and actual organic deposit or a patch of soil which has been exposed to or includes organic material
Trench A1	177	Grey sandy gravel – mixed bands of clay, sand and gravel, silty clay	Fill of ditch
Trench A1	178	Orange grey sandy gravel	Earliest deposit of the ditch – layer through natural event
Trench A1	179	Cut for construction trench for wall 114	Filled with 117
Trench A4	180	Red brick bounded with mortar – linear in plan	Ship building yard outer wall – street wall
Trench A4	181	Concrete block – with circular metal pole which has been cut at base	Concrete posthole for street lamp – within the ship yard
Trench A4	182	Sandstone blocks – dressed to the west – running north/south across trench bounded with mortar	Early wall behind rick wall (180) – running along road/street
Trench A4	183	Brown silty/sand with inclusions of demolition rubble	Rubble fill layer – demolition
Trench A4	184	Concrete slab 6 metres long – running northeast/southwest – rectangular metal lined insert (185) in centre of concrete	Working platform – industrial – possible related to shipyards
Trench A4	185	Metal lined rectangular insert in concrete block (184)	Possible inspection hatch in garage – associated with shipyards
Trench A4	186	Brown silty matrix – with inclusions of industrial material – brick and rubble	In fill within metal lined insert (185) within concrete slab (184)
Trench A4	187	Brown silty matrix	Demolition – levelling martial
Trench A4	188	Dark brown silty sand with inclusions of plastic, metal charcoal, etc.	Disturbed and mixed cobble stone
Trench A4	189	Concrete slab – lots of cracks – looks almost like paving	Concrete slab under cobbles
Trench A4	190	Cobble stones – set in yellow\orange sand – running northwest/southeast	Small pocket of in-situ cobbles stones with in (188) – shipyard court yard or road
Trench A4	191	Cobble stones	Cobbled surface – shipyards court yard or road

<i>Area</i>	<i>Context</i>	<i>Description</i>	<i>Interpretation/Relationships</i>
Trench A1	192	Foundation cut – likely to be L shape with steep sides	Foundation cut for sandstone structure (193) and possible culvert – truncates ditch [131]
Trench A1	193	Unbounded sandstone structure that is L shape in plan – oriented approximately east/west	Sandstone building – possibly related to dye works or tenement – relate to (197, 255)[254]
Trench A1	194	Grey/brown clayish silt	Main fill of foundation cut [192] – this fill has been deposited above a possible culvert
Trench A1	195	Brown silt and grey silty clay	Lower fill of foundation cut [192] – may be same as (194) but this fill is drier and much less sticky – related to {192}(193, 194)
Trench A1	196	Mottled orange and brown mix of dye (orange) and clayish silt	Deposit of material associated with the dye works
Trench A1	197	Sandstone that appears to be un-bonded – the structure is probably linear but not full uncovered	Wall of a building – possibly and extension of (193) that was put in place at a later date – could be dye works or tenement
Trench A1	198	Sandstone block	Lower (but not necessarily lowest) course of stones in (193)
Trench A1	199	Grey/blue clay	Like (175, 177) this is fairly natural deposit
Trench A1	200	-	-
Trench A1	201	Yellow brown sand	Re-deposited natural
Trench C1	202	Brown/grey silty clay with inclusions of root, plastic and stone and rubble	Topsoil with dump martial mixed in – at verge of disused car park
Trench C1	203	Red gravel	Red blaze - Levelling deposit of car park
Trench C1	204	Black tar	Tarmac for car park
Trench C1	205	Black ashy silty gravel – inclusions of tar and charcoal	Levelling for car park
Trench C1	206	Light brown silty clay	Natural clay
Trench C1	207	Mixed brown/grey silty clay with inclusions of charcoal	Re-deposited clay
Trench C1	208	Brown silty clay with inclusions of brick, stone and bubble – drainage pipe (240)	Demolition deposit
Trench C1	209	Cut of linear feature running east/west across the trench	Services trench
Trench C1	210	Light brown silty sand	Lower fill of services trench [209]
Trench C1	211	Black ash with inclusion of charcoal and cinders etc	Fill of services trench [209]
Trench C1	212	Black/brown silt with inclusions of brick, brick dust and charcoal with lenses of yellow/light brown sand	Fill of services trench [209] levelling material
Trench C1	213	Black/brown silty sand with inclusions of stone brick and rubble	Demolition rubble
Trench C1	214	Red brick – bonded with white mortar – linear running east/west	Brick wall within cut [216]
Trench C1	215	Grey/brown silty sand with inclusions of stone	Lower fill of wall [216]
Trench C1	216	Linear feature 60cm deep running east/west across the trench	Foundation cut for red brick wall – filled by (215) and (214)
Trench C1	217	Black/brown silty sand with patches of clay and inclusions of ash and brick dust	Demolition rubble – levelling martial
Trench C1	218	Yellow/white silty sand with inclusions of rubble and charcoal	Sand lenses – interface between (217, 208)

<i>Area</i>	<i>Context</i>	<i>Description</i>	<i>Interpretation/Relationships</i>
Trench C1	219	Concrete block with inclusions of red brick and sand stone	Concrete block within cut [221]
Trench C1	220	Concrete block running east/west	Upper concrete block with in [221] foundation trench
Trench C1	221	Linear cut running east west across the trench	Foundation trench for concrete wall (220, 219, 222, 223)
Trench C1	222	Brown silty clay with inclusions of charcoal	Upper deposit to the south of (220) part of the fill for [221]
Trench C1	223	Yellow/light brown sand	Bedding sand around concrete block (219) – within cut [221]
Trench C1	224	Light brown silty sand/gravel with inclusions of rubbish and roots (area over grown)	Over grown vegetation at edge of car park – on same level as re blaze (203)
Trench C1	225	Yellow/light brown silty sand	Natural sand
Trench C1	226	Dark brown loosely compacted silty gravel with inclusions of small rounded stone	Fill of drainage trench
Trench C1	227	Light red/pink silt with inclusions of brick dust, brick, stone etc	Demolition rubble
Trench C1	228	Dark brown silty clay with inclusions of roots	Possible garden soil
Trench C1	229	Brown silt sand with inclusions of rubble, sand stone, brick, china	Demolition rubble
Trench C1	230	Light brown silt with inclusions of flattish stones	Small deposit of stones within (227)
Trench C1	231	Linear feature running east west across the trench	Foundation trench for wall – filled by brick (238), concrete (232)
Trench C1	232	Concrete block	Concrete within foundation trench [231], lower part of wall
Trench C1	233	Linear cut of wall – running east /west across trench	Front wall to the south of was [231] – with services pipes between – filled by (236, 237, 234)
Trench C1	234	Concrete block	Concrete lintel
Trench C1	235	Dark brown silty clay with inclusions of charcoal, brick and rubble – lead pipe within this context	Fill of service trench – between {233 and 231}, cut 241
Trench C1	236	Concrete block	Concrete block – foundation
Trench C1	237	linear arrangement of red bricks over concrete block (236) within cut [233]	Red bricks
Trench C1	238	Red brick wall – running east/west – mortared 3 courses deep	Brick wall
Trench C1	239	Concrete block	Concrete block
Trench C1	240	Clay pipe within context (208)	Clay pipe – drainage
Trench C1	241	Cut for 235, probably truncated	Cut for service trench
Trench C1	242	Sandstone blocks with yellow mortar – running east/west	Sandstone wall behind brick wall [243] – possibly toppled from [243]
Trench C1	243	Red brick wall	Brick wall
Trench C1	244	Large concrete block – cutting into clay (206) – sits on top of (243)	Concrete block
Trench C1	245	Brick wall running east/west – return of wall can be seen on plan 17/21 which runs north/south) – 5 courses evident, bedded in sand	Small brick wall – possible out building – within cut [246]
Trench C1	246	Linear cut of wall (245) filled with sand (247)	Cut of wall – filled by (245, 247)

<i>Area</i>	<i>Context</i>	<i>Description</i>	<i>Interpretation/Relationships</i>
Trench C1	247	Yellow/white sand with inclusions of small stone	Sand used to level bricks – within cut [246]
Trench C1	248	Linear field drain running southwest/northeast across trench	Field drain
Trench A1	249	Dark grey silty clay	Although a silty clay deposit, this is similar to (199, 177, 175)
Trench A1	250	Brown silty sand clay with inclusions of charcoal flecks	Similar to (004) – represents an earlier deposit associated with the lower deposit (175)
Trench A1	251	Dark grey gritty sand silt with inclusions of red brick and yellow sandstone	Destruction layer of building debris – possibly from structure (193)
Trench A1	252	Yellow sandstone and gritty sand in a light grey/yellow sand	Destruction deposit from sandstone building – possibly from structure (193) – related to (251), could have been deposited during construction of shipyard
Trench A1	253	Linear feature orientated northwest/southeast with straight sides and flat base	Foundation cut of wall [114]
Trench A1	254	Linear feature with straight sides to flat base	Foundation of structure (55) cut has been made though demolition deposits (251, 252)
Trench A1	255	Yellow sandstone structure bonded with lime mortar – linear in shape with straight	Sandstone structure that postdates (193) – tenement?
Trench A1	256	Dark grey sandy silt	Low sandy silty fill of the Doomster Hill ditch – early
Trench A5	257	Grey/golden sandy clay – re-deposited	Re-deposited upper fill of [260]
Trench A5	258	Grey/brown clay	Upper clay deposit of [260]
Trench A5	259	Golden yellow sand	Natural sand with mixed banding of upper part - darker due to clay deposit above leaching down
Trench A5	260	Linear cut with steep straight sides to flat base (not full exposed) running north/south through trench, slight turn to the east	Cut of culvert – associated with shipyard
Trench A5	261	Grey/brown and yellow clay sand	Fill of culvert [260] – re-deposited natural
Trench A5	262	Sandstone structure – dry stone – orientated east/west over culvert	Capping stone over culvert – within cut [260]
Trench A5	263	Mortared red brick lining of culvert [260] – curvilinear in plan	Brick lining of culvert at west end of trench A5
Trench A5	264	Linear shape in plan with steep sides to flat base	Cut of modern drain – filled by (265)
Trench A5	265	Dark grey clay	Fill of (264)
Trench A5	266	Cut of linear feature steep sides to flat	Cut of modern disused pipe base
Trench A5	267	Grey/brown silty clay	Fill of cut for pipe
Trench A5	268	Yellow/brown sand with slight silty element	Natural deposit relate to (259) but with more inclusions – possibly an old water course (river Clyde)
Trench A5	269	Linear cut running east/west	Cut of linear feature of unknown function and unknown date

<i>Area</i>	<i>Context</i>	<i>Description</i>	<i>Interpretation/Relationships</i>
Trench A5	270	Grey/brown silt with patches of yellow sand and brown clay with frequent whole pieces of red and yellow brick, red ceramic tiles, metal piping and pieces of plastic	Fill of [269] deposit of building material that relates to earlier buildings on this site – demolition
Trench A5	271	Grey brown silty sand and building debris	Heavily compacted patches of (270) related to destruction of a building(s)
Trench A5	272	Dark grey gravel and black silt	Deposit may have been used as levelling
Trench A5	273	Mortared bounded red brick wall faced with concrete – linear in shape and oriented approximately east/west – bricks are only visible in places	Wall relating to Harland and Wolff shipyard – related to wall (273)
Trench A5	274	Red brick wall with concrete surround – mortar bonded – linear in plan	Wall foundation that is part of Harland and Wolff
Trench A5	275	Bonded red brick wall with concrete and red brick surrounding it – linear in plan running approximately north/south	Wall foundation that dates to Harland and Wolff use of the site – related to (273, 274)
Trench A5	276	Bonded red brick and concrete wall at north edge of trench	Wall foundation associated with Harland and Wolff – related to (273, 274, 275)
Trench A5	277	Light brown silty sand with inclusions of pieces of red brick	Infill of building debris between wall foundation of Harland and Wolff – shipyard construction
Trench A5	278	Concrete faced red brick structure shaped like the letter ‘F’ (back to front) – structure has 3 linear metal bancs running lengthways across each component – possible runways for cranes or lifting equipment	Working area of Harland and Wolff – shipyard possibly bays for welding or other industrial activity
Trench A5	279	Brown silt and building rubble (red brick pieces, small angular stone, sandstone chunks)	Fill of north shipbuilding slump – building debris – possibly form demolition of Harland and Wolff
Trench A5	280	Brown silty and building debris including red brick pieces and broken red ceramic tiles	Upper fill of shipbuilding slump at east end of trench 5 – building debris
Trench A5	281	Brown silty and building debris including red brick pieces and broken red ceramic tiles	Building debris from demolition of shipyard
Trench A5	282	Capstones for culvert at east end of trench	Capstones for culvert
Trench A5	283	Sandstone capping brick lining of culvert at east end of trench	Capping stones brick lining
Trench A5	284	Gravel	Car park gravel
Trench A5	285	Rubble comprising of brick, brick bust, concrete, plastic, pipe (clay and metal) and some loosely compacted silt	Demolition rubble from shipyard
Trench A5	286	Red gravel	Red blaes – levelling deposit prior to site’s use as a car park
Trench A5	287	Brick – cement bonded	Brick wall – associated with shipyard
Trench A5	288	Linear mortared sandstone wall – truncated by brick wall (287)	Sandstone wall – possible earlier that shipyard
Trench A5	289	Dark grey clay sand	Fill of drainage ditch – small pipe in-situ
Trench A5	290	Black ash and tar with inclusions of pieces of red tile	Possible bedding material around sandstone blocks (288)
Trench A5	291	Grey/dark grey tar and silt with frequent	Probably material used to bed-in sandstone wall (288)

<i>Area</i>	<i>Context</i>	<i>Description</i>	<i>Interpretation/Relationships</i>
Trench A5	292	Dirty yellow sand with patches of brown silt	Levelling layer above cut for culvert at east of site – look's like re-deposited natural (259)
Trench A5	293	Brown silt with patches of grey/brown clay and pockets of dirty yellow sand – inclusions of building debris, red brick, slates, red tiles and glass	Possibly the fill of cut for culvert at east end of trench
Trench A5	294	Mid brown silt with bands and patches of light brown/yellow clay – with inclusions frequent pieces of clinker and a moderate number of sub-rounded stone	Possibly a re-deposition of material – may be related to the construction of the culvert or the shipyard
Trench A5	295	Red brick and concrete	Concrete wall foundations from shipyard
Trench A5	296	Grey concrete chunks and pieces of red brick	Rubble and concrete fill in concrete wall foundation (295) – stabilising material or levelling
Trench A5	297	Red brick and concrete structure – orientated west southwest/east northeast	Lower part of wall foundation at east end of trench
Trench A5	298	Mixed deposit of brown silt and yellow sand – found between sand stone slabs (282) and above sandstone slab (283)	Possibly bedding for sandstones above and at each side of the culvert
Trench A5	299	Linear cut running east/west	Cut for drain – filled by (289) – truncates [300] is truncated by (287)
Trench A5	300	Cut of pit with steep near vertical sides flat base	Cut of pit – filled by (301) – similar to pits found in trench A1 which are associated with dye works
Trench A5	301	Black silty clay	Fill of pit [300] – similar to pits associated with dye works
Trench A5	302	Brick cement building	Brick wall – truncated by drain [260] and pit [300] – possibly associated with shipyard
Trench A5	303	Linear cut	Cut of foundation trench for brick wall [302] been truncated by [260, 300]
Trench A5	304	Black silty clay	Fill of foundation trench for wall (302) – possibly associated with shipyard
Trench A5	305	Yellow/orange clay – with occasional coal/charcoal flecks	Clay deposit – possibly associated with bricks (302) later than pit [300]
Trench A5	306	Linear or curvilinear cut – only seen in section in slot at east end of trench	Cut for culvert – filled by (293, 282, 283)
Trench A5	307	Orange/brown silty clay	Lower clay deposit under shipyard concrete
Trench A5	308	Brown ash and brick debris with occasional broken brick	Debris used to level ground – after shipyards went out of use
Trench A7	309	Possible linear feature – orientated north/south	Possible cut for a feature which may be related to the Doomster Hill – but is very disturbed
Trench A7	310	Mixed yellow/brown silty sand with occasional charcoal flecks	Possibly fill of a ditch – truncated by (316, 312)
Trench A7	311	Mixed sandy deposit – dark grey with yellow sand lenses sand	Natural deposit
Trench A7	312	Dark brown sandy clay	Sandy clay similar to (310) – truncated by (316)

<i>Area</i>	<i>Context</i>	<i>Description</i>	<i>Interpretation/Relationships</i>
Trench A7	313	Brown clay	May be a pit relating to the dye works
Trench A7	314	Black clay	Possibly related to the dye works as deposit is similar to those associated with the dye works
Trench A7	315	Orange/brown clay	Dump material associated with dye works pit
Trench A7	316	Mixed debris grey/black rubble, debris, brick	Debris – made/levelled ground – probably laid down after shipyards were abandoned
Trench A7	317	Dirty yellow sand	Natural sand
Trench A7	318	Dark grey sandy clay	Mixed sandy clay deposit similar to (311)
Trench A7	319	Light brown clay	Clay deposit
Trench A7	320	Linear cut running roughly northeast/southwest	Cut of pit of unknown function – probably relating to shipyard – wall foundation cut – filled by (321)
Trench A7	321	Dark brown silt and mid brown clay mix with inclusions of clinker	Min fill of pit [320]
Trench A5	322	Round pit	Cut of pit – filled by (323) – associated with dye works
Trench A5	323	Grey/black silty clay	Fill of pit [322]
Trench A1	324	Sandstone blocks – dressed and bonded with lime mortar	Foundation wall – possible tenements
Trench A3	325	Dark grey silty/sand with frequent inclusions of stone, brick and rubble	Rubble backfill of upper part of shipyards services trench 142
Trench C3	326	Brown loam with frequent inclusions of rubble and rubbish	Topsoil in trench C3
Trench C3	327	Concrete block	Concrete surface – shipyard
Trench C3	328	Unknown shape in plan (most likely linear) – sloping sides to rounded base	Cut of service trench – shipyard
Trench C3	329	Light brown /grey mixed silty sand and gravels	Back fill – possible relates to shipyard or road
Trench C3	330	Yellow sand with occasional lenses of clay	Natural sand
Trench C3	331	Unknown shape in plan – sloping sides to slightly concave rounded base	Cut of pit – pre dating concrete (327) – filled by (332)
Trench C3	332	Grey brown clay with sand banding	Re-deposited clay and sand fill of pit [331]
Trench C3	333	Unknown shape in plan – gradually sloping straight sides to flat base	Cut of pit pre dating concrete 327
Trench C3	334	Grey/yellow – darker at base – layers of clay then sand	Re-deposited clay and sand – fill of pit (333)
Trench C3	335	Unknown shape in plan straight sides to flat base	Cut of pit – filled by (336) – pre dating concrete 327
Trench C3	336	Black mixed silt clay and ash	Fill of pit [335] – pre dating concrete 327
Trench C2	337	Cobble surface with kerb	-
Trench C2	338	Concrete surface	Concrete surface- shipyard
Trench C2	339	Gravel service trench	-
Trench C2	340	Cut for 339	Cut for service trench filled by 339
Trench C2	341	Mixed brown sand and clay	Re-deposited natural
Trench C2	342	Concrete foundation	shipyard
Trench C2	343	Loose concrete rubble	Fill of previous trial trench
Trench C2	344	Concrete foundation	shipyard
Trench C2	345	Smooth concrete surface with channels	shipyard

<i>Area</i>	<i>Context</i>	<i>Description</i>	<i>Interpretation/Relationships</i>
Trench C2	346	Lens grey sandy clay	Re-deposited
Trench A2	347	Brick structure in SE corner	-
Trench A2	348	Concrete foundations for 347	-
Trench A2	349	Mid brown silt fill of 230	-
Trench A2	350	Grey/black ashy fill of 230	-
Trench A2	351	Sand lens within 367	-
Trench A2	352	Grey/black silt within 367	-
Trench A2	353	Mid brown silt fill of 368	-
Trench A2	354	Dark grey/black fill of 355	-
Trench A2	355	Cut of conical pit filled with 354	-
Trench A2	356	Clean brown silt fill of 357	-
Trench A2	357	Cut for pit filled with 356	-
Trench A2	358	Grey/brown silt fill of 359	-
Trench A2	359	Small pit filled with 357 & cut by 360	-
Trench A2	360	Cut for large pit	-
Trench A2	361	Lower fill of 360	-
Trench A2	362	Main fill of 365	-
Trench A2	363	Light grey brown silt fill of 365	-
Trench A2	364	Mixed grey/black silt, fill of 366	-
Trench A2	365	Cut for large pit	-
Trench A2	366	Cut for large pit – cuts 365	-
Trench A2	367	Cut for pit filled with 351 & 352	-
Trench A2	368	Cut for pit filled with 353	-
Trench A2	369	Cut for pit cut into pit 130	-
Trench A2	370	Concrete possible surface within 127	-
Trench A2	371	Lenses of re-deposited sand and silt within 372	-
Trench A2	372	Cut for 371	-
Trench A1	373	cobblestone and brick surface in S extension	-

13.3 *List of Finds*

<i>Area</i>	<i>Find No</i>	<i>Context No</i>	<i>No of Pieces</i>	<i>Material</i>	<i>Type</i>	<i>Description</i>
A1	1	004	1	Ceramic	Glazed	Medieval green glaze
A1	2	045	1	Glass	-	Early 19th sherds
A1	4	004	1	Ceramic	Glazed	Green glaze body sherd
A1	5	004	1	Ceramic	Glazed	Green glaze body sherd
A1	6	004	2	Ceramic	Glazed	Green glaze body sherd
A1	7	111	1	Ceramic	Glazed	Green glaze body sherd
A1	8	110	1	Ceramic	Glazed	Green glaze
A1	9	004	1	Ceramic	Glazed	Base sherd form dye works pit
A1	10	112	1	Ceramic	Glazed	Green glaze rim sherd
A1	11	004	1	Ceramic	Glazed	Green glaze body sherd
A2	12	113	1	Ceramic	Glazed	Mixed china
A1	13	u/s	10	Ceramic	Glazed	Mixed china
A1	14	004	15	Ceramic	Glazed	Green glaze body sherd
A1	15	004	2	Bone	Animal	Fragments
A1	16	004	2	Stone	Shale	possible marked/grooved
A1	17	004	1	Stone	Shale	Fragments
A1	18	004	2	Glass	-	Fragments
A1	19	004	1	Stone	Shale	Fragments
A1	20	004	2	Ceramic	Clay	Clay pipe
A1	21	004	2	Industrial waste	Iron	-
A1	22	004	2	Ceramic	Glazed	Green glaze body sherd
A1	23	004	1	Ceramic	Glazed	Green glaze
A1	24	004	16	Ceramic	Glazed	Mixed body sherds

<i>Area</i>	<i>Find No</i>	<i>Context No</i>	<i>No of Pieces</i>	<i>Material</i>	<i>Type</i>	<i>Description</i>
A1	25	004	1	Ceramic	Glazed	Possible white gritty sherd
A1	26	004	1	Stone	Shale	Round worked piece
A1	27	004	1	Ceramic	Clay	Roof tile
A1	28	004	3	Metal	Iron	Nails/arrow head
A1	29	117	1	Metal		Coin
A1	30	147	4	Ceramic	Glazed	Brown glazed body base and handle
A1	31	147	23	Ceramic	Glazed	Blue/white body and rim, base
A1	32	147	4	Glass	Green	Base, body and rim
A1	33	147	2	Industrial waste	Poss flint	Nodules?
A1	34	147	2	Ceramic	Glazed	Red earthen ware base and body sherd
A1	35	144	1	Stone		Possibly worked
A1	36	144	2	Ceramic	Glazed	Green glaze body sherd
A1	37	131	1	Glass	clear	Thin fine fragments
A1	38	131	5	Ceramic	Clay	Clay pipe
A1	39	131	1	Shell	Whelk	Broken
A1	40	131	14	Ceramic	Glazed	Medieval pot base, body and rim
A1	41	U/S	17	Ceramic	Glazed	Modern base body and rim
A1	42	004	2	Ceramic	Glazed	15th century green glaze
A1	43	Lower clay	7	Ceramic	Glazed	Body and rim sherd
A1	44	Lower clay	3	Stone	Slate	worked
A1	45	Lower clay	1	Stone	-	Gaming piece?
A1	46	004	1	Ceramic	Glazed	Hand painted base and body sherd
A1	47	Lower clay	4	Metal	Iron	Corroded iron clips
A1	48	Lower clay	Many	Bone	Animal	Various pieces
A1	49	004	1	Metal	-	Coin
A1	50	004	16	Ceramic	Glazed	Varies medieval rim, base and body shards
A1	51	004	2	Stone	Slate	Worked
A1	52	004	1	Ceramic	Clay	Pipe
A1	53	004	1	Glass	Green	Bottle base
A1	54	117	3	Glass	Green	Bottle base and two sherds
A1	55	117	1	Ceramic	Glazed	Large jug sherd
A1	56	117	10	Ceramic	Glazed	Fine china and early hand painted pieces
A1	57	117	8	Ceramic	Glazed	Red ceramic with black glaze
A1	58	Lower clay	3	Ceramic	Glazed	Medieval green glaze
A1	59	Lower clay	20	Ceramic	Glazed	Medieval and modern
A1	60	004	22	Ceramic	Glazed	Medieval green glaze
A1	61	117	33	Ceramic	Glazed	Modern base body and rim
A1	62	196	2	Ceramic	Glazed	Black glazed body and handle
A1	63	196	3	Glass	-	Black /dark brown body and base

<i>Area</i>	<i>Find No</i>	<i>Context No</i>	<i>No of Pieces</i>	<i>Material</i>	<i>Type</i>	<i>Description</i>
A1	64	195	2	Ceramic	Glazed	Green glaze
A1	65	195	1	Ceramic	Glazed	Green glaze
A1	66	194	10	Ceramic	Glazed	Body rim and base earthenware
A1	67	194	24	Ceramic	Glazed	Body base and rim sherds
A1	68	194	4	Ceramic	Clay	Pipe stems
A1	69	194	2	Metal	fe	Nail
A1	70	194	1	Stone	Slate	-
A1	71	194	1	Leather	-	Leather fragment
A1	72	144	7	Ceramic	Glazed	Handle and body green glaze
A1	73	194	5	Glass	-	Neck and body sherds
A1	74	-	-	-	-	-
A1	75	178	13	Ceramic	Glazed	Almost complete pot green glaze sherds
A1	76	178	9	Ceramic	Glazed	Almost complete pot green glaze sherds
A1	77	178	14	Ceramic	Glazed	Mixed pieces of green glaze sherds
A1	78	178	12	Ceramic	Glazed	Medieval pit green glaze
A1	79	178	1	Bone	Animal	Fragments
A1	80	004	1	Ceramic	Glazed	Body and rim pieces of green glaze
A1	81	177	1	Ceramic	Glazed	Green glaze base
A1	82	177	16	Ceramic	Glazed	Green glaze sherds
A1	83	177	1	Ceramic	Glazed	Green glaze
A1	84	177	2	Ceramic	Glazed	Base sherds
A1	85	177	1	Glass	-	Bottle base
A1	86	177	3	Glass	-	Window/bottle glass
A1	87	199	5	Glass	-	Bottle fragments
A1	88	199	15	Ceramic	Glazed	Various body sherds green glaze
A1	89	199	2	Ceramic	Glazed	Green glaze handles
A1	90	199	1	Ceramic	Glazed	Base
A1	91	199	1	Bone	Animal	Tooth
A1	92	199	1	Wood	Charcoal	-
A1	93	249	15	Ceramic	Glazed	Various sherds
A1	94	249	6	Ceramic	Glazed	Sherds from singlw pot?
A1	95	249	1	Ceramic	Glazed	Handle
A1	96	249	3	Bone	Animal	Fragments
A1	97	175	5	Ceramic	Glazed	Drain
A1	98	175	18	Ceramic	Glazed	Body sherds
A1	99	175	3	Ceramic	Glazed	Rim
A1	100	175	2	Ceramic	Glazed	Handles
A1	101	175	1	Ceramic	Clay	Pipe stems
A1	102	175	2	Bone	Animal	-
A1	103	175	4	Glass	-	Bottle
A1	104	117	1	Wood	-	Possibly roots
A1	105	117	1	Ceramic	Clay	Pipe stems
A1	106	117	1	Ceramic	Glazed	Drain
A1	107	117	2	Glass	Green	Bottle
A1	108	004	5	Stone	Shale	-
A1	109	004	1	Glass	Green	Bottle
A1	110	U/S	1	Ceramic	Glazed	Green glaze
A1	111	Lower clay ditch	1	Ceramic	Clay	Pipe stems
A1	112	U/S	5	Ceramic	Glazed	Green glaze

<i>Area</i>	<i>Find No</i>	<i>Context No</i>	<i>No of Pieces</i>	<i>Material</i>	<i>Type</i>	<i>Description</i>
A1	113	U/S	15	Ceramic	Glazed	Modern china
A1	114	U/S	1	Industrial waste	-	Nodules?
A1	115	U/S	1	Ceramic	Clay	Pipe stems
A1	116	U/S	5	Glass	Clear	Bottle/window
A1	117	U/S	2	Metal	-	Coin
A1	118	U/S	1	Ceramic	Clay	Pipe stems
A1	119	U/S	6	Ceramic	Glazed	Modern

13.4 List of Samples

<i>Area</i>	<i>Sample No</i>	<i>Context No</i>	<i>Size</i>	<i>Reason for Sampling</i>					<i>Application</i>
				<i>Pot</i>	<i>Bone</i>	<i>Lithics</i>	<i>Botanics</i>	<i>Other</i>	
Trench A1	(k)001	085, 086, 087						Micromorphology	J McKenzie 12/11/07
Trench A1	(k)002	086						Micromorphology	J McKenzie 12/11/07
Trench A1 Slot 2	003	144	2xL	x	x		x		Fill of ditch [131]-south trench extension
Trench A1 Ditch slot	(k)004							Micromorphology	Kubiena tins, parallel to OSL dating samples form the Doomster ditch
Trench A1 Ditch slot	(k)005							Micromorphology	Kubiena tins, parallel to OSL dating samples form the Doomster ditch
Trench A1 Ditch slot	(k)006							Micromorphology	Kubiena tins, parallel to OSL dating samples form the Doomster ditch
Trench A1 Ditch slot	(k)007							Micromorphology	Kubiena tins, parallel to OSL dating samples form the Doomster ditch
Trench A1 Ditch slot	(k)008							Micromorphology	Kubiena tins, parallel to OSL dating samples form the Doomster ditch
Trench A1 Ditch slot	(k)009							Micromorphology	Kubiena tins, parallel to OSL dating samples form the Doomster ditch
Trench A1 Ditch	010	174	L	x	x		x	Bulk sample	Top layer of ditch [003]
Trench A1 Ditch	011	004	L	x	x		x	Bulk sample	From upper ditch
Trench A1 Ditch	012	250	L	x	x		x	Bulk sample	Similar to 004 (more clay)
Trench A1 Ditch	013	175	L	x	x		x	Bulk sample	Mid fill of ditch

Area	Sample No	Context No	Size	Reason for Sampling					Application
				Pot	Bone	Lithics	Botanics	Other	
Trench A1 Ditch	014	199	L	x	x		x	Bulk sample	Lower clay fill
Trench A1 Ditch	015	178	L	x	x		x	Bulk sample	Lowest fill of ditch lot of pot
Trench A1 Ditch	016	249	L	x	x		x	Bulk sample	Similar to (177) lot of pot
Trench A1 Ditch	017	177	L	x	x		x	Bulk sample	Mixed gravels and clay
Trench A1 Ditch	018		L	x	x		x	Bulk sample	Just above sand at base
Trench A1	(k)019	087 (bottom), 086 (top)						Micromorphology	Interface between Natural sand and old ground surface
Trench A1	(k)020	086 (bottom), 085 (top)						Micromorphology	Interface between old ground surface and mixed sand
Trench A1	(k)021	085 (bottom), 074 (top)						Micromorphology	Interface between mixed sand and ditch fill
Trench A1	022	036	L	x	x		x	Bulk sample	Old ground surface
Trench A1	023	074	L	x	x		x	Bulk sample	Ditch upper fill

13.5 List of Drawings

Area	Drawing No	Sheet No	Subject	Contexts	Scale
A1	1	1	West facing section	-	1:20
A1	2	2	North facing section	-	1:20
A1	3	3	East facing section centre of trench	-	1:20
A1	4	4	West facing section northern extension	-	1:20
A1	5	5	Pre excavation plan of trench A1	-	1:50
A1	6	6	Pre excavation plan of trench A1 2 nd sheet	-	1:50
A1	7	7	East facing section – south end of trench A1	-	1:50
A1	8	8	South facing section – south end of trench	-	1:10
A1	9	9	Pre excavation plan trench A2	-	1:20
A2	10	7	North facing section trench A2	-	-
A2	11	10	Southeast facing section of ditch ant south extension	-	1:10
A1	12	10	Post excavation of slot	-	1:20
A1	13	11	North facing section – east end of trench	-	1:20
A3	14	12	Pre excavation plan of trench A3	-	1:20
A3	15	13	Plan of deeper trench in middle of A3	-	1:20
A5	16	11	North facing section –west end of trench A3	-	1:20
A4	17	14	Pre excavation plan	-	1:20
A1	18	15	Southwest facing section in the time team trench	-	1:10
A1	19	15	Southeast facing section in the time team trench	-	1:10
A4	20	16	South facing section trench A4 middle	-	1:20
C1	21	17	Pre excavation plan of trench C1	-	1:20

<i>Area</i>	<i>Drawing No</i>	<i>Sheet No</i>	<i>Subject</i>	<i>Contexts</i>	<i>Scale</i>
A1	22	18	Southeast facing section – slot 2 – south extension	(132) [192] (196)	1:10
A1	23	19	Mid excavation plan – slot thru ditch	-	1:20
A1	24	19	Elevation – south facing section at north of slot thru ditch	-	1:10
C2	25	20	South facing section trench C2	-	1:10
C2	26	21	Plan of C2	-	1:20
A1	27	22	South extension A1	-	1:20
C1	28	23	West facing section C1	-	1:20
A1	29	24	West facing section of ditch slot	-	1:10
A1	30	25	Southeast facing section of south extension	-	1:10
A1	31	26	West facing second of wall 114	-	1:10
A1	32	27	Southwest facing section	-	1:10
A1	33	28	Overlay of drawing # 7 – showing OSL samples	-	1:20
A1	34	29	West facing section of ditch slot – showing OSL samples	-	1:20
A1	35	30	Post excavation plan of ditch slot	-	1:20
A1	36	18	West facing section of slot 2 – south extension	193, 197	1:10
A5	37	31	Plan of A5 – west end – 1 st section	-	1:20
A5	38	32	Plan of A5 – west end – 2 nd section	-	1:20
A5	39	33	East facing section of culvert	-	1:10
A5	40	33	North facing section of culvert	-	1:10
A5	41	34	Plan of A5 – east end – 3 rd section	-	1:20
A5	42	35	Plan of A5 – east end – 4 th section	-	1:20
A5	43	36	North facing section	-	1:10
A5	44	37	South facing section	-	1:20
A5	45	38	Southeast facing section – test pit 1	-	1:10
A7	46	39	West facing section trench A7	-	1:20
A7	47	39	East facing section trench A7	-	1:20
A7	48	40	Plan of trough and extension	-	1:20
A5	49	28	South facing section – test pit	-	1:10
A7	50	40	North facing section – west extension	-	1:20
A5	51	28	North facing section – test pit	-	1:20
C3	52	41	E facing section – N end of Trench	-	1:20
C3	53	41	E facing section – S end of Trench	-	1:20

13.6 *List of Photographs*

Colour Print Film 1

<i>Area</i>	<i>Frame</i>	<i>Context No</i>	<i>Subject</i>	<i>Taken From</i>
A1	1	-	Pre excavation shot	N
A1	2	-	Pre excavation shot	SW
A1	3	-	General working shot- east end of trench A1	W
A1	4	-	General shot, west end trench A1 after 1 st clean	W
A1	5	-	General shot, west end trench A1 after 1 st clean	N
A1	6	-	General shot, mid trench, after 1 st clean	N
A1	7	-	General shot, mid and west end of trench, after 1 st clean	SE
A1	8	-	General shot, east end of trench, after 1 st clean	SW
A1	9	-	General shot, mid and east end of trench, after 1 st clean	SW
A1	10	-	North facing section - west trench (east end of section)	N
A1	11	-	North facing section - west trench (mid end of section)	N
A1	12	-	North facing section - west trench (west end of section)	N
A1	13	-	East facing section – west trench	E
A1	14	-	East facing section (with drain pipes)	E
A1	15	-	General shot – west facings section – north end of trench A1	SW

GUARD

<i>Area</i>	<i>Frame</i>	<i>Context No</i>	<i>Subject</i>	<i>Taken From</i>
A1	16	-	West facing section – (north end) – north end of trench A1	W
A1	17	-	West facing section – (south end) – north end of trench A1	W
A1	18	-	North facing section and large drain – north end of trench A1	N
A1	19	-	General shot of surveying	N
A1	20	-	Large drain and section – north end of trench A1	SW
A1	21	-	General working shot	NW
A1	22	-	East facing section – north end of trench A1	E
A1	23	-	East facing section – north end of trench A1	E
A1	24	-	Concrete and brick floor – north end of trench A1	E
A1	25	-	Concrete and brick floor – north end of trench A1	E
A1	26	-	General shot of site	NE
A1	27	-	Concrete and brick floor – north end of trench A1	NW
A1	28	-	General shot of concrete floor – east end of trench A1	NW
A1	29	-	General shot of concrete floor – east end of trench A1	N
A1	30	-	General shot of concrete and metal base – east end of trench A1	W
A1	31	-	General shot of concrete and metal base – east end of trench A1	SW
A1	32	-	General shot of concrete floor	SE
A1	33	-	North facing section (time team trench)	N

Colour Print Film 2

<i>Area</i>	<i>Frame</i>	<i>Context No</i>	<i>Subject</i>	<i>Taken From</i>
A1	1	-	East facing section – west end of possible ditch	E
A1	2	[030]	Post excavation shot – time team trench	W
A1	3	-	South facing section – time team trench	S
A1	4	[021] (022)	North facing section – south of 1996 trench	NW
A1	5	(002) [021] (022)	North facing section – southwest end of trench	N
A1	6	-	West facing section of north of	W
A1	7	(064)	Detail shot of wall	W
A1	8	(005) (006) (007) (002)(018) (019) (020)	East facing section – southwest end of trench	E
A1	9	-	West facing section – north of trench – deepened	SW
A1	10	-	West facing section – north of trench – deepened	NW
A1	11	-	West facing section of northern extension	W
A1	12	-	Detail shot of lower deposits of northern extension	W
A1	13	-	Detail shot of brick wall in northern extension	W
A1	14	-	South facing section – west end section – centre of trench A1	SW
A1	15	-	South facing section – west end section – centre of trench A1	WSW
A1	16	-	South facing section – east end section – centre of trench A1	SW
A1	17	-	South facing section – east end section – centre of trench A1	S
A1	18	-	South facing section – centre of trench A1	SE
A1	19	-	Area to south of south facing section – east end	N
A1	20	-	Previous 1990 trench back fill	N
A1	21	-	Previous 1990 trench back fill	S

GUARD

<i>Area</i>	<i>Frame</i>	<i>Context No</i>	<i>Subject</i>	<i>Taken From</i>
A1	22	-	General shot of A1 centre after 2 nd clean	NW
A1	23	-	General shot of A1 centre after 2 nd clean	E
A1	24	-	General shot of A1 centre after 2 nd clean	N
A1	25	-	General shot of A1 centre after 2 nd clean	W
A1	26	-	General shot of A1 centre after 2 nd clean	SW
A1	27	-	General shot of A1 centre southeast after 2 nd clean	NE
A1	28	-	General shot of A1 centre southeast after 2 nd clean	NE
A1	29	-	General shot of A1 centre southeast after 2 nd clean	SW
A1	30	-	Trench A1 south after 2 nd Clean	N
A1	31	-	Trench A1 south after 2 nd Clean	SW
A1	32	-	Trench A1 south after 2 nd Clean	S

Colour Print Film 3

<i>Area</i>	<i>Frame</i>	<i>Context No</i>	<i>Subject</i>	<i>Taken From</i>
A1	1	-	General working shot – east end of Trench A1	SW
A1	2	-	Tenement wall after 2 nd clean	SW
A1	3	-	Tenement wall after 2 nd clean	N
A1	4	-	Tenement wall after 2 nd clean	W
A1	5	-	Southwest facing section – east end of trench A1	SW
A1	6	-	Southwest facing section – east end of trench A1	NW
A2	7	-	Pre excavation shot	S
A2	8	-	Pre excavation shot	W
A2	9	-	Pre excavation shot	SW
A2	10	-	Pre excavation shot	E
A2	11	-	Pre excavation shot	SW
A1	12	-	General working shot – excavation of ditch	E
A2	13	-	Southeast facing section wall	SE
A2	14	-	North facing section trench A2	NE
A2	15	-	North facing section trench A2	NE
A2	16	-	Pre excavation shot of trench	W
A2	17	-	Detail of southeast facing section	S
A2	18	-	Big Chain	
A2	19	-	North side of slipway wall – dressed face	N
A2	20	-	North side of slipway wall – dressed face	NW
A2	21	-	North side of slipway wall and trench	NW
A2	22	-	West facing section trench A2	W
A1	23	-	Mid excavation of slot thru ditch at south extension	E
A1	24	-	Southeast facing section of slot thru ditch	SE
A3	25	-	North facing section – east end of trench	NE
A3	26	-	North facing section – east end of trench	N
A1	27	-	North facing section – east end of trench	NW
A1	28	-	Detail of potter in ditch slot	S
A1	29	[131] (132)	Southeast facing section of slot at south extension	S
A1	30	[131] (132)	Post excavation of slot at south extension	W
A1	31	[131] (132)	Slot in site context	SE
A1	32	003	Record shot of ditch partially excavated	NW
A1	33	003	Record shot of ditch partially excavated	NW
A1	34	-	Working shot of slot through ditch	N
A1	35	-	General shot of site	E
A1	36	-	General shot of site	ESE

Colour Print Film 4

<i>Area</i>	<i>Frame</i>	<i>Context No</i>	<i>Subject</i>	<i>Taken From</i>
A3	1	-	General shot - pre excavation of trench A3	W
A3	2	-	General shot - pre excavation of trench A3	E
A3	3	-	Detail shot of concrete slab	W
A3	4	-	Detail shot of cobbled road surface	E
A3	5	-	North facing section trench A3 - 7 m from west end	N
A3	6	-	South facing section trench A3 – 7 m from west end	S
A3	7	-	South facing section trench A3 – 7 m from west end	SW
A3	8	-	Detail of wall in north facing section	N
A3	9	-	Section above wall in north facing section	N
A3	10	-	Wall at base of west facing section	NW
A1	11	-	Detail of tenement foundation in south extension	W
A1	12	-	General view of tenement foundation in south extension	W
A1	13	-	Ditch shot at end of day - 7/11/07	NW
A4	14	-	Pre excavation shot	E
-	15	-	-	W
-	16	-	-	-
-	17	-	-	-
-	18	-	-	-
A1	19	-	In situ pot/wood in ditch slot	S
A1	20	-	Time team trench (partiality reopened)	SW
A1	21	-	Time team trench – southwest facing section	SW
A1	22	-	Time team trench – southeast facing section	SE
A4	23	-	Cobbles at southeast end of trench	SE
A4	24	-	Cobbles at southeast end of trench	W
A4	25	-	General shot of trench A4 from west end	W
A4	26	-	Detail shot of road front	S
A4	27	-	Detail shot of concrete	SW
A4	28	-	Concrete floor under cobble stones	SW
A4	29	-	Detail shot of disturbed cobbles	SW
A4	30	-	Southwest facing section	SW
A4	31	-	North facing section	NE
A1	32	-	East facing section at extreme west limit of area showing original ground surface	E
A1	33	-	Post slot at extreme west limit of site showing ditch	S
A1	34	-	Slot thru ditch at west	S
A1	35	-	Slot thru ditch at west – detail shot	W
A1	36	-	Mid excavation of slot 2 – south extension	SW
A1	37	-	Mid excavation of slot 2 – south extension	SW

Colour Print Film 5

<i>Area</i>	<i>Frame</i>	<i>Context No</i>	<i>Subject</i>	<i>Taken From</i>
A1	1	178	In situ pot	S
A1	2	-	Cobble stone at west end of slot 2 – south extension	S
A1	3	178	In situ pot	S
C3	4	-	Test pit at south end of trench into sand	SE
C3	5	-	Test pit at south end of trench into sand	E
C1	6	-	General shot of trench	S
C1	7	-	General shot of trench	W
C1	8	-	Detail of wall with damp course	W
C1	9	-	Detail of walls at south end of trench	W
C3	10	-	East facing section – south end of trench	E
C3	11	-	General shot of trench – south of test pit	W

<i>Area</i>	<i>Frame</i>	<i>Context No</i>	<i>Subject</i>	<i>Taken From</i>
C3	12	-	West facing section – north end of trench	W
C3	13	-	General shot of trench – north of test pit	W
C3	14	-	General shot of pits in east facing section	NE
C2	15	-	Southeast facing section through clay	SE
C2	16	-	General shot of southwest end of trench	SW
C2	17	-	General shot of northeast end of trench	NE
C2	18	-	Cobbled and kerb at northeast end of trench	SW
A1	19	-	Post excavation of slot	S
A1	20	-	Post excavation of slot	S
A1	21	-	Post excavation of slot	N
A1	22	-	West facing section of ditch	SW
A1	23	(144) [192] (196)	Slot 2 and sandstone structures in south extension	W
A1	24	-	Post excavation of ditch slot	S
A1	25	-	Post excavation of ditch slot	S
A1	26	-	West facing section - shots running from south to west along section	SW
C1	27	-	West facing section - shots running from south to west along section	W
C1	28	-	West facing section - shots running from south to west along section	W
C1	29	-	West facing section - shots running from south to west along section	W
C1	30	-	West facing section - shots running from south to west along section	W
C1	31	-	West facing section - shots running from south to west along section	W
C1	32	-	West facing section - shots running from south to west along section	W
C1	33	-	Oblique view of west facing section	NW
C1	34	-	Oblique view of west facing section	NW
C1	35	-	Oblique view of west facing section	NW
C1	36	-	Oblique view of west facing section	NW

Colour Print Film 6

<i>Area</i>	<i>Frame</i>	<i>Context No</i>	<i>Subject</i>	<i>Taken From</i>
C1	1	-	General shot showing sand and clay	N
A1	2	-	General working shot	W
A1	3	-	General working shot	SW
A1	4	-	General working shot	E
A5	5	-	Pre excavation shot	E
A5	6	-	Pre excavation shot	W
A1	7	-	GUL OLS dating tubes of A1 in east facing section	E
A1	8	-	OLS dating tubes in ditch	W
A1	9	-	OLS dating tubes in ditch	W
A1	10	-	Close up of bottom of ditch with OLS dating tubes	W
A5	11	-	West end of trench – rubble	N
A5	12	-	West end of trench – rubble	N
A5	13	-	West end of trench – rubble on	NW
A1	14	114	West facing section of wall	W
A1	15	114, 115, 111, 253	West facing section	SW
A1	16	-	Sand in east facing section A1 with poss. lenses and OSL tubes	E

GUARD

<i>Area</i>	<i>Frame</i>	<i>Context No</i>	<i>Subject</i>	<i>Taken From</i>
A1	17	-	Sand in east facing section A1 with poss. lenses and OSL tubes	E
A1	18	(193) (197)	West facing section of structures	W
A5	19	-	General shot of south facing section – wall and sand	NW
A5	20	-	General shot of south facing section – wall and sand	NE
A5	21	-	General shot of culvert	N
A5	22	-	West facing section – middle of trench A5	N
A5	23	-	Working shot of trench	NE
A5	24	-	Detail shot of sandstone wall – west end of trench	N
A5	25	-	Detail shot of sandstone wall – west end of trench	N
A5	26	-	Detail shot of brick wall – south facing section – west end of trench	S
A5	27	-	Detail shot of cut (wall) – west end of trench	E
A5	28	-	Detail shot, two wall foundation – east end of trench	N
A5	29	-	Detail of wall foundation and robbed out wall – east end of trench	E
A5	30	-	Detail of walls – east end of trench	E
A6	31	-	General shot of trench onto concrete and sand	S
A6	32	-	Detail of kubiena tins in ditch	W

Colour Print Film 7

<i>Area</i>	<i>Frame</i>	<i>Context No</i>	<i>Subject</i>	<i>Taken From</i>
A6	1	-	General shot of 2 nd layer of concrete	S
A6	2	-	West facing section onto 2 nd layer of concrete	W
A6	3	-	East facing section onto 2 nd layer of concrete	E
A5	4	-	Detail of concrete structure	NE
A5	5	-	Detail of concrete structure	NE
A5	6	(282) (283)	Drainage culvert – east end of trench	N
A5	7	292, 295, 278, 282, 283, 297, 298, 296	North facing section of deposits at culvert	N
A5	8	-	East facing section of deposits at culvert	E
A5	9	-	General working shot	E
-	10	-	General shot from quayside	S
-	11	-	General shot from quayside	SE
-	12	-	General shot from quayside	S
-	13	-	General shot from quayside	SW
-	14	-	General shot from quayside	W
A5	15	-	Test pit 1 – southeast facing section	SE
A5	16	-	Test pit 1 – southeast facing section	SW
A5	17	-	Test pit 1 – detail shot	SE
A7	18	-	West facing section	W
A7	19	-	West facing section	SW
A7	20	-	East facing section	E
A7	21	-	Northwest facing section	NW
A7	22	-	East facing section	SE
A7	23	-	North facing section – west extension	N
A7	24	-	South facing section – west extension	S
A7	25	-	General shot of trench	NE
A85	26	-	Test pit – north facing section	N
A5	27	-	Test pit – south facing section	S
A8	28	-	Test pit beside Clyde concrete floor	S
A8	29	-	Test pit beside Clyde, showing concrete floor	W

Mono Film 8

<i>Area</i>	<i>Frame</i>	<i>Context No</i>	<i>Subject</i>	<i>Taken From</i>
A1	1	-	Pre excavation shot	N
A1	2	-	Pre excavation shot	SW
A1	3	-	General working shot- east end of trench A1	W
A1	4	-	General shot, west end trench A1 after 1 st clean	W
A1	5	-	General shot, west end trench A1 after 1 st clean	N
A1	6	-	General shot, mid trench, after 1 st clean	N
A1	7	-	General shot, mid and west end of trench, after 1 st clean	SE
A1	8	-	General shot, east end of trench, after 1 st clean	SW
A1	9	-	General shot, mid and east end of trench, after 1 st clean	SW
A1	10	-	North facing section - west trench (east end of section)	N
A1	11	-	North facing section - west trench (mid end of section)	N
A1	12	-	North facing section - west trench (west end of section)	N
A1	13	-	East facing section – west trench	E
A1	14	-	East facing section (with drain pipes)	E
A1	15	-	General shot – west facings section – north end of trench A1	SW
A1	16	-	West facing section – (north end) – north end of trench A1	W
A1	17	-	West facing section – (south end) – north end of trench A1	W
A1	18	-	North facing section and large drain – north end of trench A1	N
A1	19	-	General shot of surveying	N
A1	20	-	Large drain and section – north end of trench A1	SW
A1	21	-	General working shot	NW
A1	22	-	East facing section – north end of trench A1	E
A1	23	-	East facing section – north end of trench A1	E
A1	24	-	Concrete and brick floor – north end of trench A1	E
A1	25	-	Concrete and brick floor – north end of trench A1	E
A1	26	-	General shot of site	NE
A1	27	-	Concrete and brick floor – north end of trench A1	NW
A1	28	-	General shot of concrete floor – east end of trench A1	NW
A1	29	-	General shot of concrete floor – east end of trench A1	N
A1	30	-	General shot of concrete and metal base – east end of trench A1	W
A1	31	-	General shot of concrete and metal base – east end of trench A1	SW
A1	32	-	General shot of concrete floor	SE
A1	33	-	North facing section (time team trench)	N

Mono Film 9

<i>Area</i>	<i>Frame</i>	<i>Context No</i>	<i>Subject</i>	<i>Taken From</i>
A1	1	-	East facing section – west end of possible ditch	E
A1	2	[030]	Post excavation shot – time team trench	W
A1	3	-	South facing section – time team trench	S
A1	4	[021] (022)	North facing section – south of 1996 trench	NW
A1	5	(002) [021] (022)	North facing section – southwest end of trench	N
A1	6	-	West facing section of north of	W
A1	7	(064)	Detail shot of wall	W

GUARD

<i>Area</i>	<i>Frame</i>	<i>Context No</i>	<i>Subject</i>	<i>Taken From</i>
A1	8	(005) (006) (007) (002) (018) (019) (020)	East facing section – southwest end of trench	E
A1	9	-	West facing section – north of trench – deepened	SW
A1	10	-		NW
A1	11	-	West facing section of northern extension	W
A1	12	-	Detail shot of lower deposits of northern extension	W
A1	13	-	Detail shot of brick wall in northern extension	W
A1	14	-	South facing section – west end section – centre of trench A1	SW
A1	15	-	South facing section – west end section – centre of trench A1	WSW
A1	16	-	South facing section – east end section – centre of trench A1	SW
A1	17	-	South facing section – east end section – centre of trench A1	S
A1	18	-	South facing section – centre of trench A1	SE
A1	19	-	Area to south of south facing section – east end	N
A1	20	-	Previous 1990 trench back fill	N
A1	21	-	Previous 1990 trench back fill	S
A1	22	-	General shot of A1 centre after 2 nd clean	NW
A1	23	-	General shot of A1 centre after 2 nd clean	E
A1	24	-	General shot of A1 centre after 2 nd clean	N
A1	25	-	General shot of A1 centre after 2 nd clean	W
A1	26	-	General shot of A1 centre after 2 nd clean	SW
A1	27	-	General shot of A1 centre southeast after 2 nd clean	NE
A1	28	-	General shot of A1 centre southeast after 2 nd clean	NE
A1	29	-	General shot of A1 centre southeast after 2 nd clean	SW
A1	30	-	Trench A1 south after 2 nd Clean	N
A1	31	-	Trench A1 south after 2 nd Clean	SW
A1	32	-	Trench A1 south after 2 nd Clean	S

Mono Film 10

<i>Area</i>	<i>Frame</i>	<i>Context No</i>	<i>Subject</i>	<i>Taken From</i>
A1	1	-	General working shot – east end of Trench A1	SW
A1	2	-	Tenement wall after 2 nd clean	SW
A1	3	-	Tenement wall after 2 nd clean	N
A1	4	-	Tenement wall after 2 nd clean	W
A1	5	-	Southwest facing section – east end of trench A1	SW
A1	6	-	Southwest facing section – east end of trench A1	NW
A2	7	-	Pre excavation shot	S
A2	8	-	Pre excavation shot	W
A2	9	-	Pre excavation shot	SW
A2	10	-	Pre excavation shot	E
A2	11	-	Pre excavation shot	SW
A1	12	-	General working shot – excavation of ditch	E
A2	13	-	Southeast facing section wall	SE
A2	14	-	North facing section trench A2	NE
A2	15	-	North facing section trench A2	NE
A2	16	-	Pre excavation shot of trench	W
A2	17	-	Detail of southeast facing section	S
A2	18	-	Big Chain	
A2	19	-	North side of slipway wall – dressed face	N
A2	20	-	North side of slipway wall – dressed face	NW

Mono Film 10

<i>Area</i>	<i>Frame</i>	<i>Context No</i>	<i>Subject</i>	<i>Taken From</i>
A2	21	-	North side of slipway wall and trench	NW
A2	22	-	West facing section trench A2	W
A1	23	-	Mid excavation of slot thru ditch at south extension	E
A1	24	-	Southeast facing section of slot thru ditch	SE
A3	25	-	North facing section – east end of trench	NE
A3	26	-	North facing section – east end of trench	N
A1	27	-	North facing section – east end of trench	NW
A1	28	-	Detail of potter in ditch slot	S
A1	29	[131] (132)	Southeast facing section of slot at south extension	S
A1	30	[131] (132)	Post excavation of slot at south extension	W
A1	31	[131] (132)	Slot in site context	SE
A1	32	003	Record shot of ditch partially excavated	NW
A1	33	003	Record shot of ditch partially excavated	NW
A1	34	-	Working shot of slot through ditch	N
A1	35	-	General shot of site	E
A1	36	-	General shot of site	ESE

Mono Film 11

<i>Area</i>	<i>Frame</i>	<i>Context No</i>	<i>Subject</i>	<i>Taken From</i>
A3	1	-	General shot - pre excavation of trench A3	W
A3	2	-	General shot - pre excavation of trench A3	E
A3	3	-	Detail shot of concrete slab	W
A3	4	-	Detail shot of cobbled road surface	E
A3	5	-	North facing section trench A3 - 7 m from west end	N
A3	6	-	South facing section trench A3 – 7 m from west end	S
A3	7	-	South facing section trench A3 – 7 m from west end	SW
A3	8	-	Detail of wall in north facing section	N
A3	9	-	Section above wall in north facing section	N
A3	10	-	Wall at base of west facing section	NW
A1	11	-	Detail of tenement foundation in south extension	W
A1	12	-	General view of tenement foundation in south extension	W
A1	13	-	Ditch shot at end of day - 7/11/07	NW
A4	14	-	Pre excavation shot	E
-	15	-	-	-
-	16	-	-	-
-	17	-	-	-
-	18	-	-	-
A1	19	-	In situ pot/roots in ditch slot	S
A1	20	-	Time team trench (partiality reopened)	SW
A1	21	-	Time team trench – southwest facing section	SW
A1	22	-	Time team trench – southeast facing section	SE
A4	23	-	Cobbles at southeast end of trench	SE
A4	24	-	Cobbles at southeast end of trench	W
A4	25	-	General shot of trench A4 from west end	W
A4	26	-	Detail shot of road front	S
A4	27	-	Detail shot of concrete	SW
A4	28	-	Concrete floor under cobble stones	SW
A4	29	-	Detail shot of disturbed cobbles	SW
A4	30	-	Southwest facing section	SW
A4	31	-	North facing section	NE
A1	32	-	East facing section at extreme west limit of area showing original ground surface	E
A1	33	-	Post slot at extreme west limit of site showing ditch	S

<i>Area</i>	<i>Frame</i>	<i>Context No</i>	<i>Subject</i>	<i>Taken From</i>
A1	34	-	Slot thru ditch at west	S
A1	35	-	Slot thru ditch at west – detail shot	W
A1	36	-	Mid excavation of slot 2 – south extension	SW
A1	37	-	Mid excavation of slot 2 – south extension	SW

Mono Film 12

<i>Area</i>	<i>Frame</i>	<i>Context No</i>	<i>Subject</i>	<i>Taken From</i>
A1	1	-	In situ pot	S
A1	2	-	Cobble stone at west end of slot 2 – south extension	S
A1	3	-	In situ pot	S
C3	4	-	Test pit at south end of trench into sand	SE
C3	5	-	Test pit at south end of trench into sand	E
C1	6	-	General shot of trench	S
C1	7	-	General shot of trench	W
C1	8	-	Detail of wall with damp course	W
C1	9	-	Detail of walls at south end of trench	W
C3	10	-	East facing section – south end of trench	E
C3	11	-	General shot of trench – south of test pit	W
C3	12	-	West facing section – north end of trench	W
C3	13	-	General shot of trench – north of test pit	W
C3	14	-	General shot of pits in east facing section	NE
C2	15	-	Southeast facing section through clay	SE
C2	16	-	General shot of southwest end of trench	SW
C2	17	-	General shot of northeast end of trench	NE
C2	18	-	Cobbled and kerb at northeast end of trench	SW
A1	19	-	Post excavation of slot	S
A1	20	-	Post excavation of slot	S
A1	21	-	Post excavation of slot	N
A1	22	-	West facing section of ditch	SW
A1	23	(144) [192]	Slot 2 and sandstone structures in south extension (196)	W
A1	24	-	Post excavation of ditch slot	S
A1	25	-	Post excavation of ditch slot	S
A1	26	-	West facing section - shots running from south to west along section	SW
C1	27	-	West facing section - shots running from south to west along section	W
C1	28	-	West facing section - shots running from south to west along section	W
C1	29	-	West facing section - shots running from south to west along section	W
C1	30	-	West facing section - shots running from south to west along section	W
C1	31	-	West facing section - shots running from south to west along section	W
C1	32	-	West facing section - shots running from south to west along section	W
C1	33	-	Oblique view of west facing section	NW
C1	34	-	Oblique view of west facing section	NW
C1	35	-	Oblique view of west facing section	NW
C1	36	-	Oblique view of west facing section	NW

Mono Film 13

<i>Area</i>	<i>Frame</i>	<i>Context No</i>	<i>Subject</i>	<i>Taken From</i>
C1	1	-	General shot showing sand and clay	N
A1	2	-	General working shot	W
A1	3	-	General working shot	SW
A1	4	-	General working shot	E
A5	5	-	Pre excavation shot	E
A5	6	-	Pre excavation shot	W
A1	7	-	GUL OLS dating tubes of A1 in east facing section	E
A1	8	-	OLS dating tubes in ditch	W
A1	9	-	OLS dating tubes in ditch	W
A1	10	-	Close up of bottom of ditch with OLS dating tubes	W
A5	11	-	West end of trench – rubble	N
A5	12	-	West end of trench – rubble	N
A5	13	-	West end of trench – rubble on	MW
A1	14	114	West facing section of wall	W
A1	15	114, 115, 111, 253	West facing section	SW
A1	16	-	Sand in east facing section A1 with poss. lenses and OSL tubes	E
A1	17	-	Sand in east facing section A1 with poss. lenses and OSL tubes	E
A1	18	(193) (197)	West facing section of structures	W
A5	19	-	General shot of south facing section – wall and sand	NW
A5	20	-	General shot of south facing section – wall and sand	NE
A5	21	-	General shot of culvert	N
A5	22	-	West facing section – middle of trench A5	N
A5	23	-	Working shot of trench	NE
A5	24	-	Detail shot of sandstone wall – west end of trench	N
A5	25	-	Detail shot of sandstone wall – west end of trench	N
A5	26	-	Detail shot of brick wall – south facing section – west end of trench	S
A5	27	-	Detail shot of cut (wall) – west end of trench	E
A5	28	-	Detail shot, two wall foundation – east end of trench	N
A5	29	-	Detail of wall foundation and robbed out wall – east end of trench	E
A5	30	-	Detail of walls – east end of trench	E
A6	31	-	General shot of trench onto concrete and sand	S
A6	32	-	Detail of kubiena tins in ditch	W

Mono Film 14

<i>Area</i>	<i>Frame</i>	<i>Context No</i>	<i>Subject</i>	<i>Taken From</i>
A6	1	-	General shot of 2 nd layer of concrete	S
A6	2	-	West facing section onto 2 nd layer of concrete	W
A6	3	-	East facing section onto 2 nd layer of concrete	E
A5	4	-	Detail of concrete structure	NE
A5	5	-	Detail of concrete structure	NE
A5	6	(282) (283)	Drainage culvert – east end of trench	N
A5	7	292, 295, 278, 282, 283, 297, 298, 296	North facing section of deposits at culvert	N
A5	8	-	East facing section of deposits at culvert	E
A5	9	-	General working shot	E
-	10	-	General shot from quayside	S

<i>Area</i>	<i>Frame</i>	<i>Context No</i>	<i>Subject</i>	<i>Taken From</i>
-	11	-	General shot from quayside	SE
-	12	-	General shot from quayside	S
-	13	-	General shot from quayside	SW
-	14	-	General shot from quayside	W
A5	15	-	Test pit 1 – southeast facing section	SE
A5	16	-	Test pit 1 – southeast facing section	SW
A5	17	-	Test pit 1 – detail shot	SE
A7	18	-	West facing section	W
A7	19	-	West facing section	SW
A7	20	-	East facing section	E
A7	21	-	Northwest facing section	NW
A7	22	-	East facing section	SE
A7	23	-	North facing section – west extension	N
A7	24	-	South facing section – west extension	S
A7	25	-	General shot of trench	NE
A85	26	-	Test pit – north facing section	N
A5	27	-	Test pit – south facing section	S
A8	28	-	Test pit beside Clyde concrete floor	S
A8	29	-	Test pit beside Clyde, showing concrete floor	W

Digital Film

Digital Film Photographs (file. 2497_Digital_Images_Week1_22-26Oct)

<i>Area</i>	<i>Frame</i>	<i>Context No</i>	<i>Subject</i>	<i>Taken From</i>
A1	1	-	Pre excavation shot	N
A1	2	-	Pre excavation shot	SW
A1	3	-	General working shot- east end of trench A1	W
A1	4	-	General shot, west end trench A1 after 1 st clean	W
A1	5	-	General shot, west end trench A1 after 1 st clean	N
A1	6	-	General shot, mid trench, after 1 st clean	N
A1	7	-	General shot, mid and west end of trench, after 1 st clean	SE
A1	8	-	General shot, east end of trench, after 1 st clean	SW
A1	9	-	General shot, mid and east end of trench, after 1 st clean	SW
A1	10	-	North facing section - west trench (east end of section)	N
A1	11	-	North facing section - west trench (mid end of section)	N
A1	12	-	North facing section - west trench (west end of section)	N
A1	13	-	East facing section – west trench	E
A1	14	-	East facing section (with drain pipes)	E
A1	15	-	General shot – west facings section – north end of trench A1	SW
A1	16	-	West facing section – (north end) – north end of trench A1	W
A1	17	-	West facing section – (south end) – north end of trench A1	W
A1	18	-	North facing section and large drain – north end of trench A1	N
A1	19	-	General shot of surveying	N
A1	20	-	General shot of surveying	N
A1	21	-	Large drain and section – north end of trench A1	SW
A1	22	-	General working shot	NW
A1	23	-	East facing section – north end of trench A1	E
A1	24	-	East facing section – north end of trench A1	E
A1	25	-	Concrete and brick floor – north end of trench A1	E
A1	26	-	Concrete and brick floor – north end of trench A1	E
A1	27	-	General shot of site	NE

GUARD

<i>Area</i>	<i>Frame</i>	<i>Context No</i>	<i>Subject</i>	<i>Taken From</i>
A1	28	-	Concrete and brick floor – north end of trench A1	NW
A1	29	-	General shot of concrete floor – east end of trench A1	NW
A1	30	-	General shot of concrete floor – east end of trench A1	N
A1	31	-	General shot of concrete and metal base – east end of trench A1	W
A1	32	-	General shot of concrete and metal base – east end of trench A1	SW
A1	33	-	General shot of concrete floor	SE
A1	34	[003] (004)	North facing section (time team trench)	N
A1	35	-	East facing section – west end of possible ditch	E
A1	36	-	Post excavation shot – time team trench	W
A1	37	-	South facing section – time team trench	S
A1	38	[021] (022)	North facing section – south of 1996 trench	NW
A1	39	(002) [021] (022)	North facing section – southwest end of trench	N
A1	40	-	West facing section of north of	W
A1	41	(064)	Detail shot of wall	W
A1	42	(005) (006) (007) (002) (018) (019) (020)	East facing section – southwest end of trench	E
A1	43	-	West facing section – north of trench – deepened	SW
A1	44	-	West facing section – north of trench – deepened	NW
A1	45	-	West facing section of northern extension	W

Digital Photographs (file. 2497_Digital_Images_Week2_29Oct-2Nov)

<i>Area</i>	<i>Frame</i>	<i>Context No</i>	<i>Subject</i>	<i>Taken From</i>
A1	1	-	West facing section of northern extension	W
A1	2	-	Detail shot of lower deposits of northern extension	W
A1	3	-	Detail shot of brick wall in northern extension	W
A1	4	-	South facing section – west end section – centre of trench A1	SW
A1	5	-	South facing section – west end section – centre of trench A1	WSW
A1	6	-	South facing section – east end section – centre of trench A1	SW
A1	7	-	South facing section – east end section – centre of trench A1	S
A1	8	-	South facing section – centre of trench A1	SE
A1	9	-	Area to south of south facing section – east end	N
A1	10	-	Previous 1990 trench back fill	N
A1	11	-	Previous 1990 trench back fill	S
A1	12	-	General shot of A1 centre after 2 nd clean	NW
A1	13	-	General shot of A1 centre after 2 nd clean	E
A1	14	-	General shot of A1 centre after 2 nd clean	N
A1	15	-	General shot of A1 centre after 2 nd clean	W
A1	16	-	General shot of A1 centre after 2 nd clean	SW
A1	17	-	General shot of A1 centre southeast after 2 nd clean	NE
A1	18	-	General shot of A1 centre southeast after 2 nd clean	NE
A1	19	-	General shot of A1 centre southeast after 2 nd clean	SW
A1	20	-	General working shots	SE
A1	21	-	General working shots	SE
A1	22	-	General working shots	SE
A1	23	-	General working shots	SE
A1	24	-	Trench A1 south after 2 nd Clean	N

<i>Area</i>	<i>Frame</i>	<i>Context No</i>	<i>Subject</i>	<i>Taken From</i>
A1	25	-	Trench A1 south after 2 nd Clean	SW
A1	26	-	Trench A1 south after 2 nd Clean	S
A1	27	-	General working shot – east end of Trench A1	SW
A1	28	-	Tenement wall after 2 nd clean	SW
A1	29	-	Tenement wall after 2 nd clean	SW
A1	30	-	Tenement wall after 2 nd clean	SW
A1	31	-	Tenement wall after 2 nd clean	N
A1	32	-	Tenement wall after 2 nd clean	W
A1	33	-	Southwest facing section – east end of trench A1	SW
A1	34	-	Southwest facing section – east end of trench A1	NW
A2	35	-	Pre excavation shot	S
A2	36	-	Pre excavation shot	W
A2	37	-	Pre excavation shot	SW
A2	38	-	Pre excavation shot	E
A2	39	-	Pre excavation shot	SW
A1	40	-	General working shot – excavation of ditch	E
A1	41	-	General working shot – excavation of ditch	E
A1	42	-	General working shot – excavation of ditch	E
A1	43	-	General working shot	NE
A1	44	-	General working - shot through ditch – partially excavated	SE
A1	45	-	General working - shot through ditch – partially excavated	NE
A2	46	-	Southeast facing section wall	SE
A2	47	-	North facing section trench A2	NE
A2	48	-	North facing section trench A2	NE
A2	49	-	Pre excavation shot of trench	W
A2	50	-	Detail of southeast facing section	S
A2	51	-	Big Chain	
A2	52	-	North side of slipway wall – dressed face	N
A1	53	-	North side of slipway wall – dressed face	NW
A1	54	-	North side of slipway wall and trench	NW
A1	55	-	West facing section trench A2	W

Digital Photographs (file. 2497_Digital_Images_Week3_5-9Nov)

<i>Area</i>	<i>Frame</i>	<i>Context No</i>	<i>Subject</i>	<i>Taken From</i>
A1	1	-	Pulled down fencing after weekend	W
A1	2	-	Remains of fire in trench after weekend	NE
A1	3	-	Remains of fire in trench after weekend	N
A1	4	-	Mid excavation of slot thru ditch at south extension	E
A1	5	-	Southeast facing section of slot thru ditch	SE
A3	6	-	North facing section – east end of trench	NE
A3	7	-	North facing section – east end of trench	N
A3	8	-	North facing section – east end of trench	NW
A1	9	-	Detail of potter in ditch slot	S
A1	10	-	Detail of potter in ditch slot	S
A1	11	[131](132)	Southeast facing section of slot at south extension	S
A1	12	[131](132)	Post excavation of slot at south extension	W
A1	13	[131](132)	Slot in site context	SE
A1	14	003	Record shot of ditch partially excavated	NW
A1	15	003	Record shot of ditch partially excavated	NW
A1	16	-	Working shot of slot through ditch	N
A1	17	-	General shot of site	E
A1	18	-	General shot of site	E
A1	19	-	General shot of site	E

GUARD

<i>Area</i>	<i>Frame</i>	<i>Context No</i>	<i>Subject</i>	<i>Taken From</i>
A1	20	-	General shot of site	E
A1	21	-	General shot of site	E
A1	22	-	General shot of site	E
A1	23	-	General shot of site	E
A3	24	-	General shot - pre excavation of trench A3	W
A3	25	-	General shot - pre excavation of trench A3	E
A3	26	-	Detail shot of concrete slab	W
A3	27	-	Detail shot of cobbled road surface	E
A3	28	-	North facing section trench A3 - 7 m from west end	N
A3	29	Top	South facing section trench A3 – 7 m from west end	S
A3	30	Bottom	South facing section trench A3 – 7 m from west end	S
A3	31	-	South facing section trench A3 – 7 m from west end	SW
A3	32	-	Detail of wall in north facing section	N
A3	33	-	Section above wall in north facing section	N
A3	34	-	Wall in north facing section	NW
A3	35	-	Wall at base of west facing section	
A1	36	-	Detail of tenement foundation in south extension	W
A1	37	-	General view of tenement foundation in south extension	W
A1	38	-	Ditch shot at end of day - 7/11/07	NW
A4	39	-	Pre excavation shot	E
A4	40	-	Pre excavation shot	W
A1	41	-	In situ pot/wood in ditch slot	S
A1	42	-	Time team trench (partiality reopened)	SW
A1	43	-	Time team trench – southwest facing section	SW
A1	44	-	Time team trench – southeast facing section	SE
A4	45	-	Cobbles at southeast end of trench	SE
A4	46	-	Cobbles at southeast end of trench	W
A4	47	-	General working shot	W
A4	48	-	General working shot	NW
A4	49	-	General shot of trench A4 from west end	W
A4	50	-	General shot of trench A4 from west end	W
A4	51	-	Detail shot of road front	S
A4	52	-	Detail shot of concrete	SW
A4	53	-	Concrete floor under cobble stones	SW
A4	54	-	Detail shot of disturbed cobbles	SW
A4	55	-	Southwest facing section	SW
A4	56	-	North facing section	NE
A1	57	-	East facing section at extreme west limit of area showing original ground surface	E
A1	58	-	Post slot at extreme west limit of site showing ditch	S
A1	59	-	Slot thru ditch at west	S
A1	60	-	Slot thru ditch at west – detail shot	W
A1	61	-	Mid excavation of slot 2 – south extension	SW
A1	62	-	Mid excavation of slot 2 – south extension	SW
A1	63	178	In situ pot	S
A1	64	--	Cobble stone at west end of slot 2 – south extension	S
A1	65	178	In situ pot	S
C3	66	-	Test pit at south end of trench into sand	SE
C3	67	-	Test pit at south end of trench into sand	E
C1	68	-	General shot of trench	S
C1	69	-	General shot of trench	W
C1	70	-	Detail of wall with damp course	W
C1	71	-	Detail of walls at south end of trench	W
C3	72	-	East facing section – south end of trench	E
C3	73	-	General shot of trench – south of test pit	W
C3	74	-	General shot of trench – south of test pit	W
C3	75	-	West facing section – north end of trench	W

<i>Area</i>	<i>Frame</i>	<i>Context No</i>	<i>Subject</i>	<i>Taken From</i>
C3	76	-	General shot of trench – north of test pit	W
C3	77	-	General shot of pits in east facing section	NE
C2	78	-	Southeast facing section through clay	SE
C2	79	-	General shot of southwest end of trench	SW
C2	80	-	General shot of northeast end of trench	NE
C2	81	-	Cobbled and kerb at northeast end of trench	SW
A1	82	-	Post excavation of slot	S
A1	83	-	Post excavation of slot	S
A1	84	-	Post excavation of slot	N
A1	85	-	West facing section of ditch	SW

Digital Photographs (file. 2497_Digital_Images_Week4_12-16Nov)

<i>Area</i>	<i>Frame</i>	<i>Context No</i>	<i>Subject</i>	<i>Taken From</i>
A1	1	(144) [192] (196)	Slot 2 and sandstone structures in south extension	W
A1	2	-	Post excavation of ditch slot	S
A1	3	-	Post excavation of ditch slot	S
A1	4	-	West facing section - shots running from south to west along section	SW
C1	5	-	West facing section - shots running from south to west along section	W
C1	6	-	West facing section - shots running from south to west along section	W
C1	7	-	West facing section - shots running from south to west along section	W
C1	8	-	West facing section - shots running from south to west along section	W
C1	9	-	West facing section - shots running from south to west along section	W
C1	10	-	West facing section - shots running from south to west along section	W
C1	11	-	Oblique view of west facing section	NW
C1	12	-	Oblique view of west facing section	NW
C1	13	-	Oblique view of west facing section	NW
C1	14	-	Oblique view of west facing section	NW
C1	15	-	Oblique view of west facing section	NW
C1	16	-	General shot showing sand and clay	N
C3	17	-	General shot after back filling	N
C3	18	-	General shot after back filling	N
C2	19	-	General shot after back filling	SW
C2	20	-	General shot after back filling	SW
C1	21	-	General shot after back filling	S
C1	22	-	General shot after back filling	N
A1	23	-	General working shot	W
A1	24	-	General working shot	SW
A1	25	-	General working shot	E
A1	26	-	General working shot	E
A1	27	-	General working shot	E
A5	28	-	Pre excavation shot	E
A5	29	-	Pre excavation shot	W
A1	30	-	GUL OLS dating tubes of A1 in east facing section	E
A1	31	-	OLS dating tubes in ditch	W
A2	32	-	OLS dating tubes in ditch	W
A5	33	-	West end of trench – rubble	N
A5	34	-	West end of trench – rubble	N

GUARD

<i>Area</i>	<i>Frame</i>	<i>Context No</i>	<i>Subject</i>	<i>Taken From</i>
A5	35	-	West end of trench – rubble on	NW
A1	36	-	West facing section of wall	W
A1	37	-	West facing section	SW
A1	38	-	West facing section – re taken	SW
A1	39	-	Sand in east facing section A1 with poss. lenses and OSL tubes	E
A1	40	-	Sand in east facing section A1 with poss. lenses and OSL tubes	E
A5	41	-	West facing section of structures	W
A5	42	-	General shot of south facing section – wall and sand	NW
A5	43	-	General shot of culvert	
A5	44	-	West facing section – middle of trench A5	N
A5	45	-	West facing section – middle of trench A5	N
A5	46	-	Working shot of trench	NE
A5	47	-	Detail shot of sandstone wall – west end of trench	N
A5	48	-	Detail shot of sandstone wall – west end of trench	N
A5	49	-	Detail shot of brick wall – south facing section – west end of trench	S
A5	50	-	Detail shot of cut (wall) – west end of trench	E
A5	51	-	Detail shot, two wall foundation – east end of trench	N
A5	52	-	Detail of wall foundation and robbed out wall – east end of trench	E
A5	53	-	Detail of walls – east end of trench	E
A6	54	-	General shot of trench onto concrete and sand	S
A6	55	-	General shot of trench onto concrete and sand	S
A1	56	-	Detail of kubiena tins in ditch	W
A6	57	-	General shot of 2 nd layer of concrete	S
A6	58	-	West facing section onto 2 nd layer of concrete	W
A6	59	-	East facing section onto 2 nd layer of concrete	E
A5	60	-	Detail of concrete structure	NE
A5	61	-	Detail of concrete structure	NE
A5	62	(282) (283)	Drainage culvert – east end of trench	N
A5	63	292, 295, 278, 282, 283, 297, 298, 296	North facing section of deposits at culvert	N
A5	64	-	East facing section of deposits at culvert	E
A5	65	-	General working shot	E
A1	66	-	General working shot – sampling ditch fill	S
-	67	-	General shot from quayside	SE
-	68	-	General shot from quayside	S
-	69	-	General shot from quayside	SW
-	70	-	General shot from quayside	W
A5	71	-	Test pit 1 – southeast facing section	SE
A5	72	-	Test pit 1 – southeast facing section	SW
A5	73	-	Test pit 1 – detail shot	SE
A7	74	-	West facing section	W
A7	75	-	West facing section	SW
A7	76	-	East facing section	E
	77	-		
A7	78	-	Northwest facing section	NW
A7	79	-	East facing section	E
A7	80	-	East facing section	SE
A7	81	-	East facing section	NE
A7	82	-	North facing section – west extension	N
A7	83	-	South facing section – west extension	S
A7	84	-	General shot of trench	NE

<i>Area</i>	<i>Frame</i>	<i>Context No</i>	<i>Subject</i>	<i>Taken From</i>
A5	85	-	Test pit – north facing section	N
A5	86	-	Test pit – south facing section	S
A8	87	-	Test pit beside Clyde concrete floor	S
A8	88	-	Test pit beside Clyde, showing concrete floor	W